

INSTALLATION GUIDE

AMP RESEARCH Power Step

MADE IN USA

APPLICATION	LENGTH	MODEL YR	PART #
Ford F-150 Supercrew	79"	2001-2003	75111-01A

INSTALLATION TIME

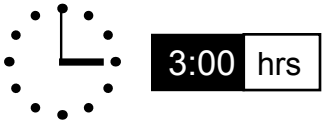

3:00 hrs

SKILL LEVEL



4= Experienced

- TOOLS REQUIRED**
- Safety goggles
 - Measuring tape
 - Flat blade screwdriver
 - Phillips head screwdriver
 - Right angle drill
 - 1/8" drill bit
 - 21/64" drill bit
 - 13mm socket
 - 10 mm socket
 - 8 mm socket
 - Ratchet wrench and extension
 - 13mm end wrench
 - Wire crimpers
 - Wire stripper / cutter
 - Vise grip pliers
 - Corrosion inhibitor
 - 3/16" hex key wrench (allen wrench)
 - 5mm hex key wrench (allen wrench)
 - 4mm hex key wrench (allen wrench)
 - Electrical tape
 - Weather proof caulking (silicone sealer)

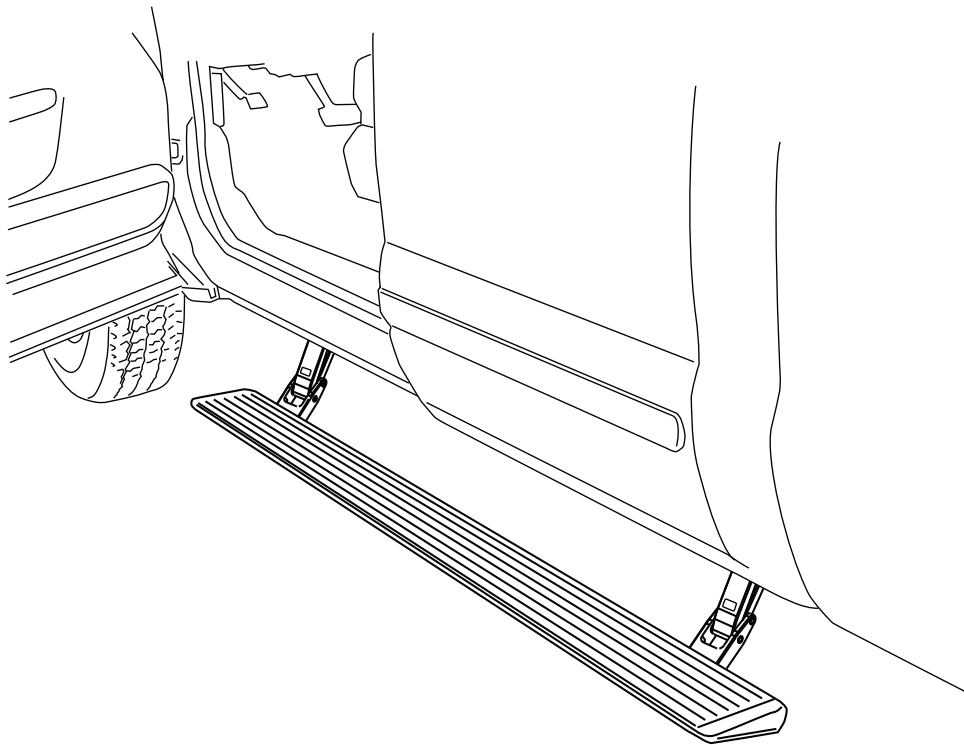

AMP RESEARCH TECH SUPPORT 1-888-983-2204 (Press 2) Monday - Friday, 6:00 AM - 5:00 PM PST

Designed and manufactured by AMP Research®. Patent Number 6,830,257; 6,641,158; 6,834,875; 6,938,909; 6,942,233; 7,007,961; 7,055,839; 7,163,221; 7,367,574; 7,380,807; 7,398,985; 7,413,204; 7,487,986. Other US and Worldwide patents pending. Made in USA © 2010 AMP Research
5-year limited warranty. Professional installation is recommended.

INSTALLATION GUIDE

Attaching motor to linkage assembly

The motors need to be installed before continuing with the rest of the Power Step install.

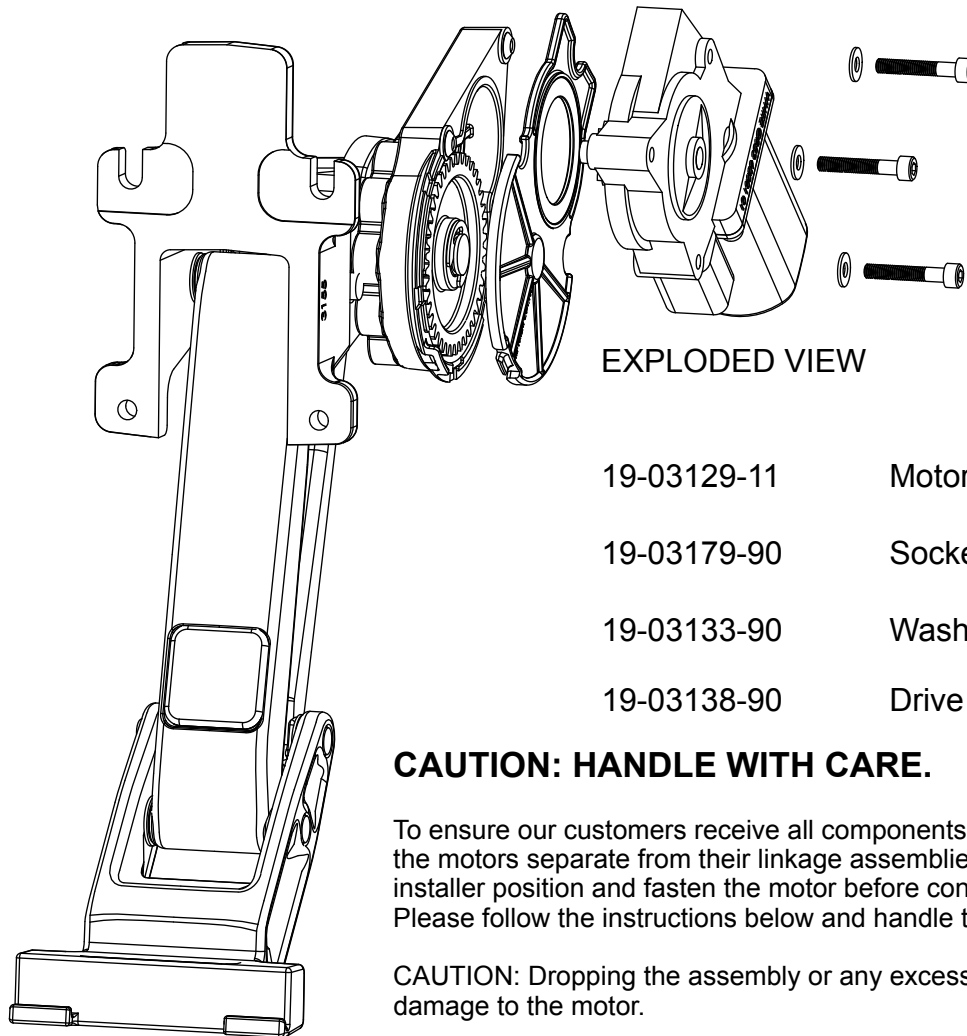

EXPLODED VIEW

19-03129-11	Motor
19-03179-90	Socket cap screw
19-03133-90	Washer
19-03138-90	Drive Gear Housing Cover

CAUTION: HANDLE WITH CARE.

To ensure our customers receive all components with full integrity, we pack the motors separate from their linkage assemblies. This requires that the installer position and fasten the motor before continuing with the install. Please follow the instructions below and handle the assembly carefully.

CAUTION: Dropping the assembly or any excessive impact MAY cause damage to the motor.

Instructions:

1. Position the gear cover in place as shown if not already in place.
2. Seat motor into position on the three mounting bosses. This may require an adjustment of the gear by moving the swing arms.
3. After seating into place, fasten the motor with the three motor mount screws with 4mm Hex Head. Tighten screws to 36 in-lbs (4N-m). **Do not over torque.**

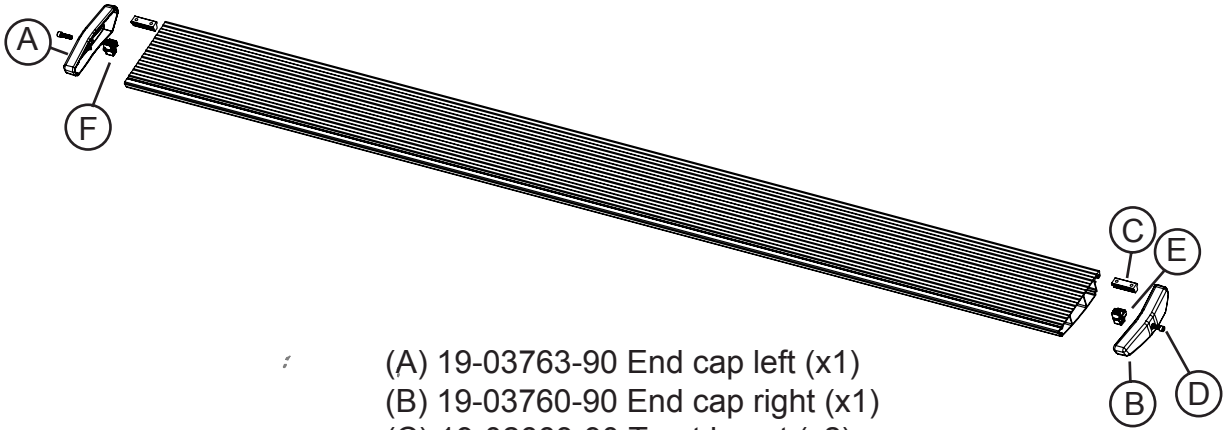

- (A) 19-03763-90 End cap left (x1)
- (B) 19-03760-90 End cap right (x1)
- (C) 19-02663-90 T-nut insert (x2)
- (D) 19-02802-90 Socket cap screw (x2)
- (E) 19-03761-90 End cap wedge right (x1)
- (F) 19-03764-90 End cap wedge left (x1)

1 x2

Running board assembly

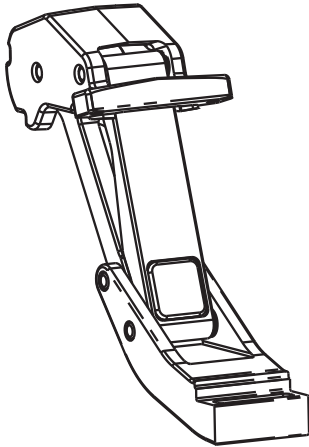

2 x2

10-03058-11
Idler linkage assembly

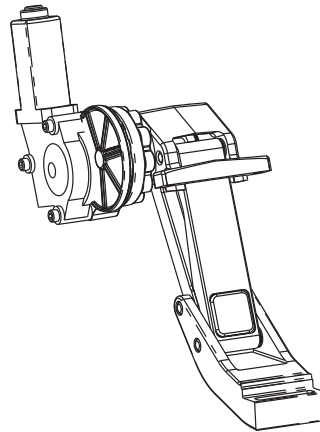

(10-03058-12 Shown)

3 x2

10-03059-12
Motor linkage assembly

NOTE: The motor is shipped separated from upper mount for part protection. Preassembly required. See page 2.

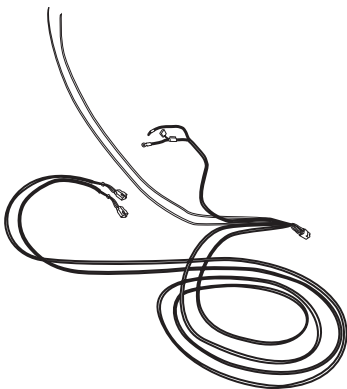

4

19-02726-91
Wire harness

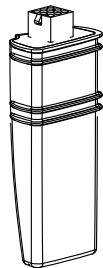

5

19-03297-93
Controller

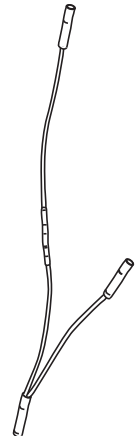

6 x4

19-02727-90
Single-diode

PARTS LIST AND HARDWARE IDENTIFICATION

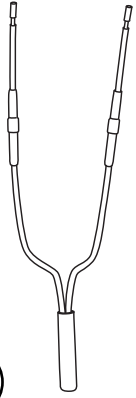

7

19-02890-90
Double Diode

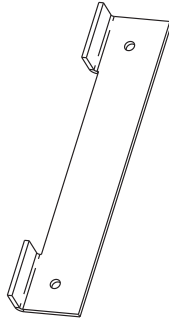

8

19-03044-90
Drill Template

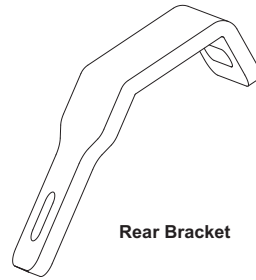

Rear Bracket

9 x2

16-03166-90
Rear Bracket

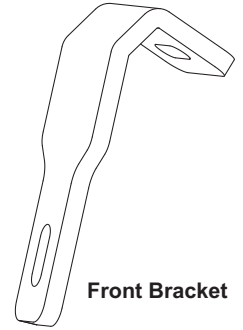

Front Bracket

10 x2

16-03165-90
Front Bracket

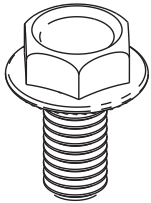

11 x4

19-03037-90
Hex Flange Bolt

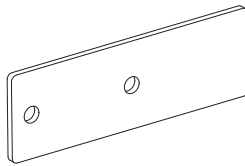

12 x2

16-03171-90
Support Bracket

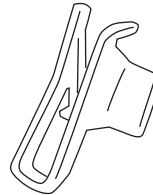

13 x6

19-02488-90
U-Nut

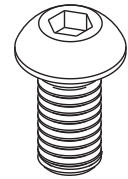

14 x8

16-02634-90
Button Head Bolt

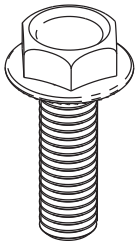

15 x6

19-02740-90
Hex Flange Bolt

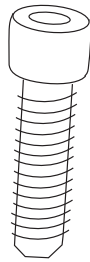

16 x8

19-02802-90
Socket Cap Screw

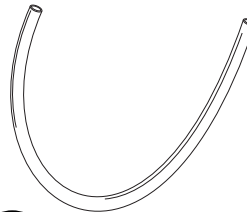

17

19-02992-90
Tubing
(Installation Tool)

18 x25

19-02805-90
Cable Ties 7"

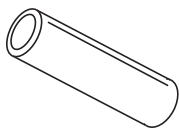

20 x2

19-02989-90
Bull Connector

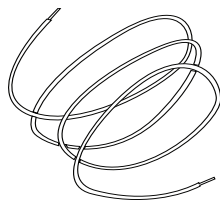

21 x2

19-02986-90
Connecting Wire Red

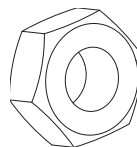

22 x8

19-03021-90
Hex Nut

19 x2

19-03339-90
Cable Ties 11"

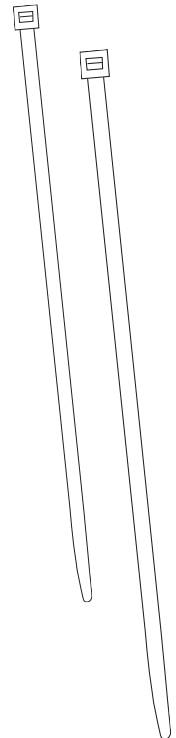

AMP RESEARCH POWER STEP – FORD F150 SUPERCREW

Install U-Nut. Drilling Rear Mounting Holes: Position and clamp drill template as shown, (center on U-Nut) and pilot drill mount holes with 1/8" drill bit. Remove template and drill holes to 21/64".

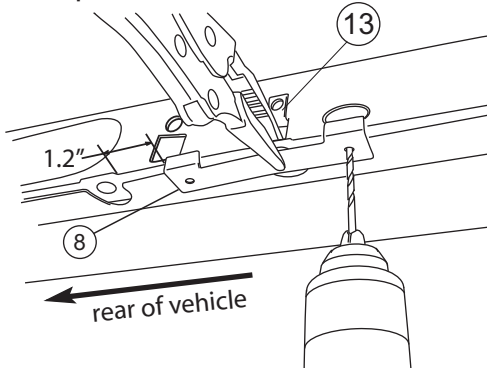

1 Note: Steps 1-9 show Driver's Side.

Install U-Nut. Drilling Forward Mounting Holes: Position and clamp drill template as shown, (center on U-Nut) centering the template around stock mounting hole.

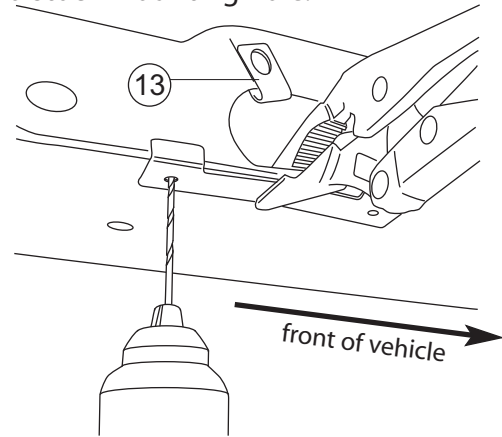

2

Mounting Rear Brackets: Install two u-nuts if not already present. Install support bracket and then install Rear Bracket. Do not tighten bolts yet.

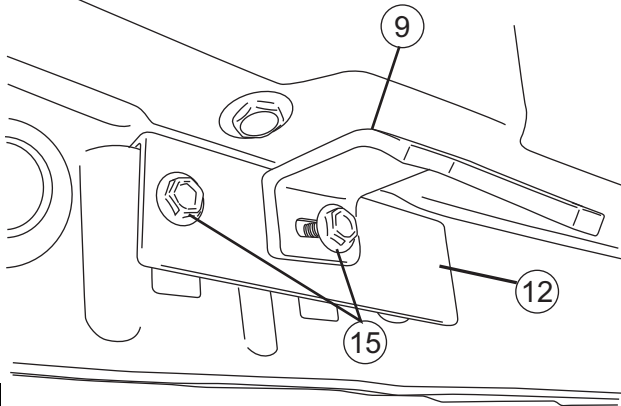

3

Position Drive Mount at rear mount location and bolt to bracket and drilled mounting holes. Snug all bolts... do not fully tighten.

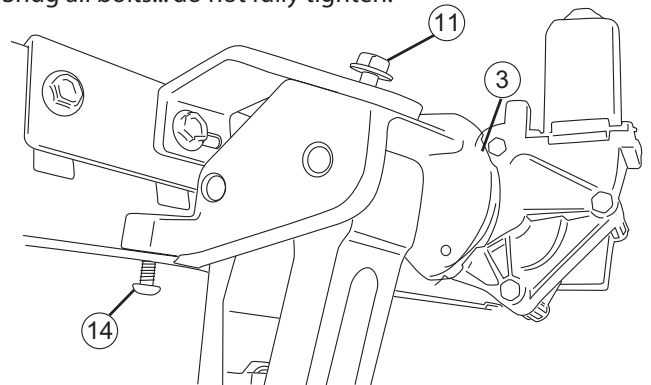

4

Mount Front Bracket to upper stock mounting hole that the drill template was centered about.

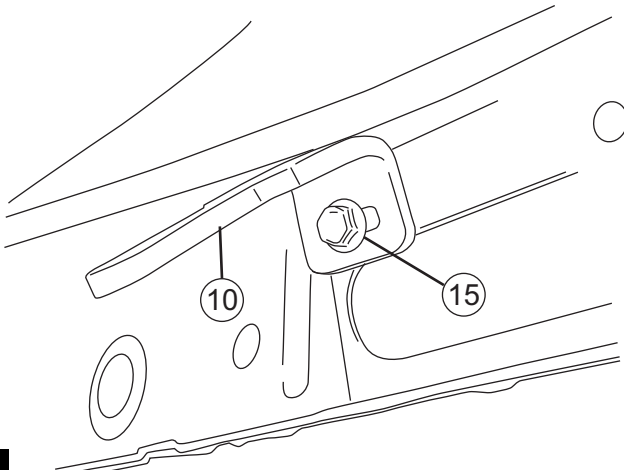

5

Position idler linkage assembly in forward mounting position and bolt to bracket and drilled mounting holes. Snug all bolts... do not fully tighten.

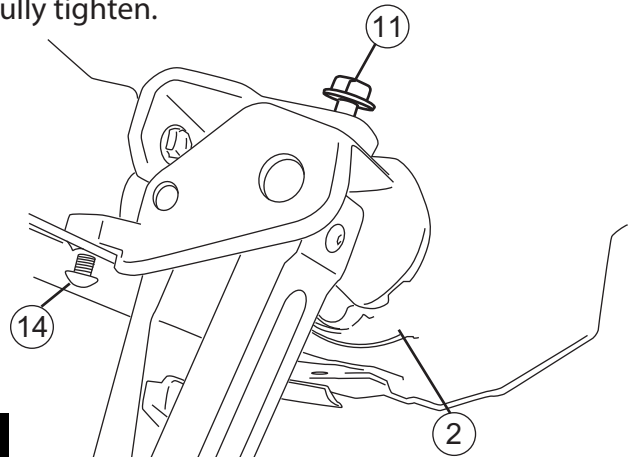

6

AMP RESEARCH POWER STEP – FORD F150 SUPERCREW

Line up T-nuts of step extrusion and insert 1/4-20 bolts. You may need to use the end of the Allen wrench to align the holes with the T-nut.

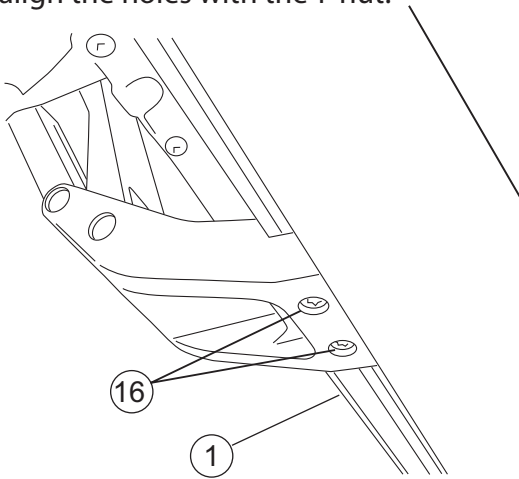

7

The rearward edge of the board should be about 9.5in from rear mount. Tighten 1/4-20 bolts to 10 ft-lbs.

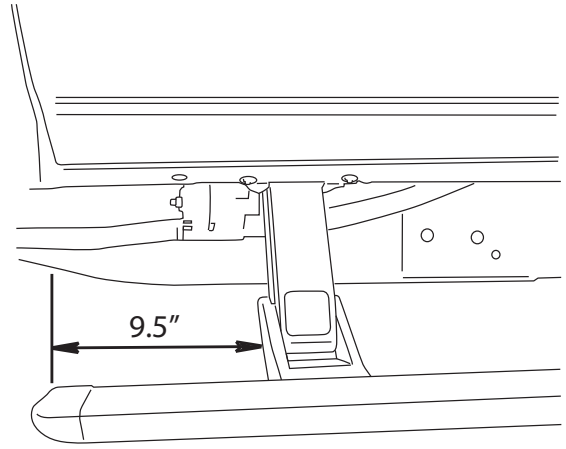

8

Tighten all bolts of steps 3-6 to 16 ft-lbs.

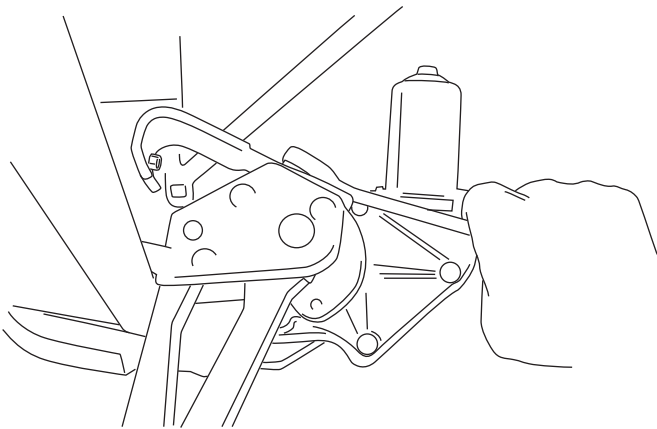

9 Repeat steps 1-9 for passenger side.

Mounting Controller: To firewall near passenger side using two supplied 11" zip ties. Start zip ties, leaving enough to insert controller.

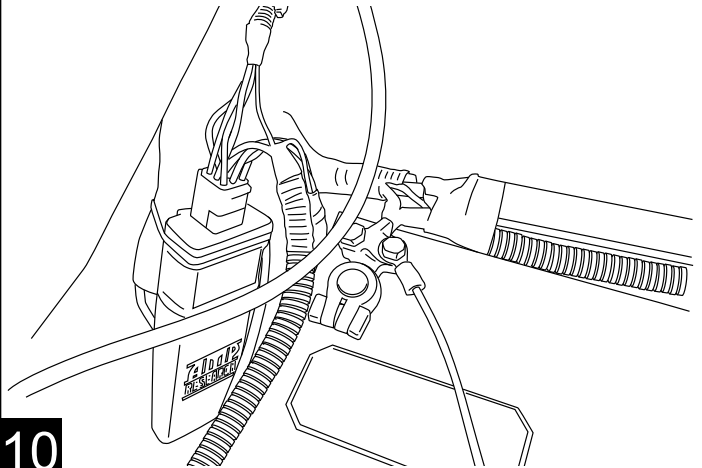

10

After removing Power Step harness fuse, attach ring terminal of the red wire to the positive battery lead and that of the black wire to the negative battery lead.

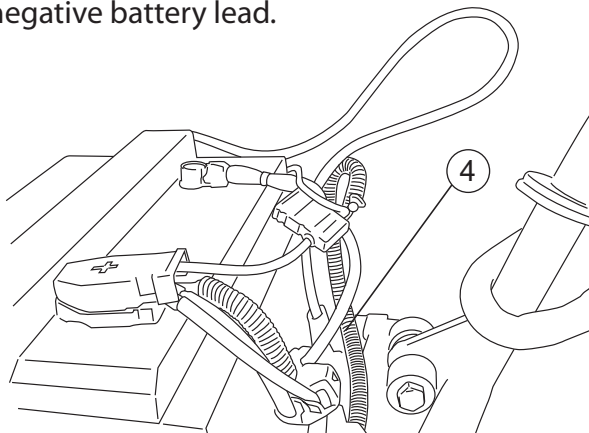

11

Route the long end of the harness along firewall and secure with tie wraps along the way.

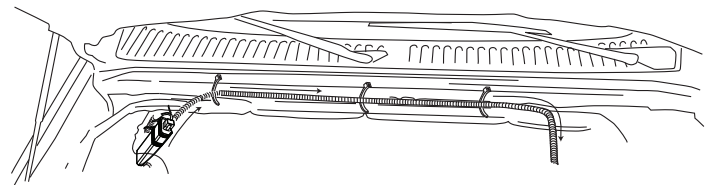

12

AMP RESEARCH POWER STEP – FORD F150 SUPERCREW

Route harness end with motor connectors down the inner side walls of truck and down along the frame to the motorized linkages. Plug connector into motor.

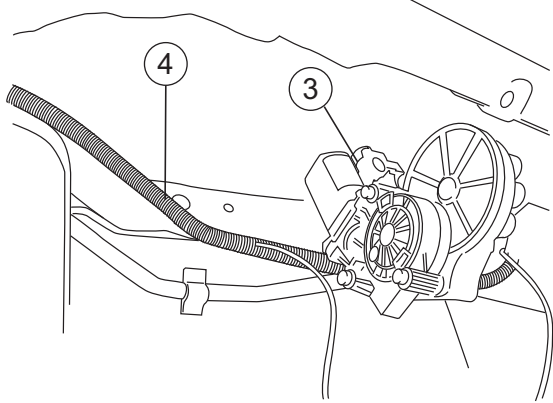

13

Pierce holes in front floor board grommets to allow access for harness trigger wire into cab of vehicle. Push purple trigger wires through pierced holes.

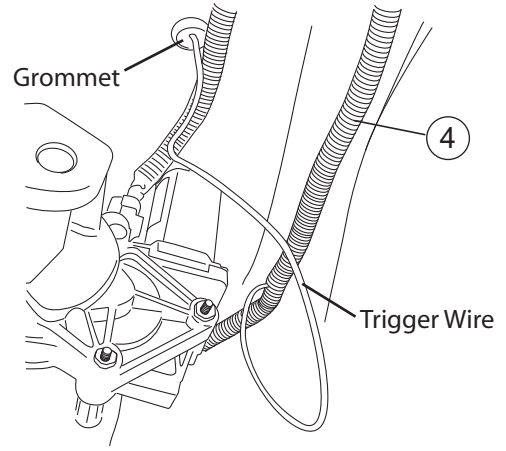

14

On each side of the vehicle measure from the front edge of door line on the pinch weld to the specified lengths below. Measure at 21" for front LED Light and 58" for rear LED Light.

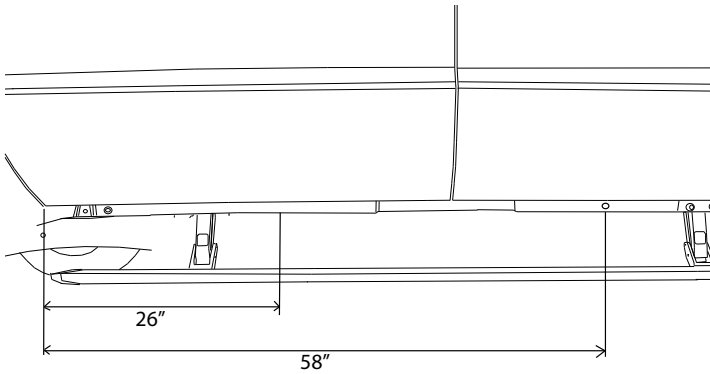

15

Affix lamps to rocker panel surface. Make sure the lamp is affixed to a clean, flat surface. There is a step down midway across the surface. Affix lamp just outside of step down.

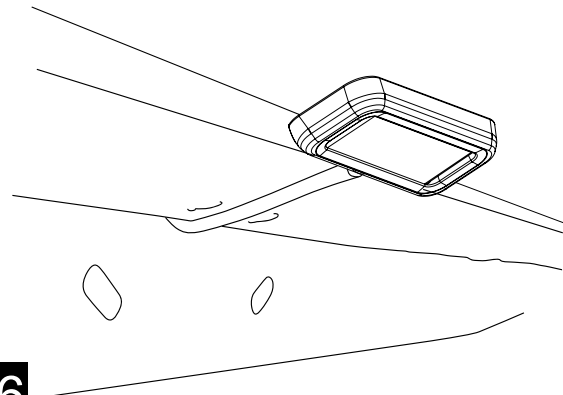

16

Using supplied butt connectors, connect the lamp wires. Red to Red, Black to Black

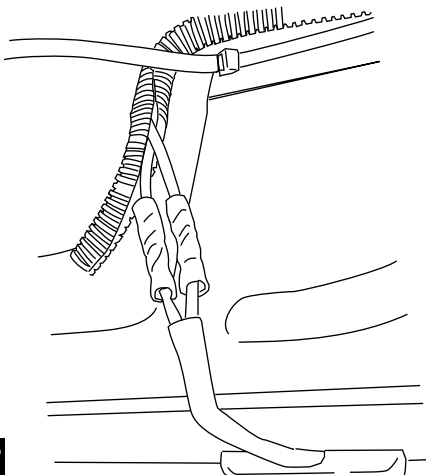

17

Close and wrap with conduit and electrical tape. Secure all loose wires with cable ties, with lamp wires pulled upward to avoid any wire snagging.

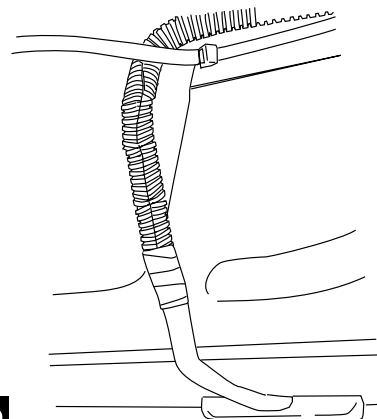

18

AMP RESEARCH POWER STEP – FORD F150 SUPERCREW

Remove driver side step plate and kick panel. Of the three connectors to the left of the parking brake pedal, locate the top connector. Splice single diode harness into Black with Yellow stripe wire, diode end away from connector as shown in figure.

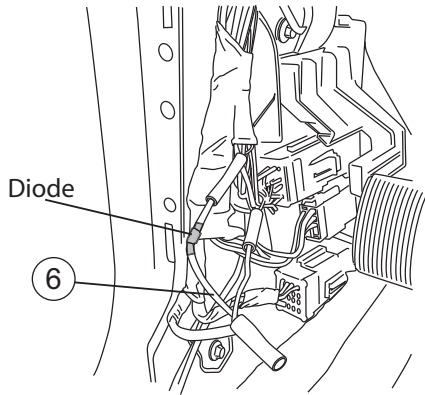

Locate harness bundle under driver sill plate, open bundle and find Black with Light Blue stripe wire. Splice into wire single diode harness with the diode end toward the front of the vehicle.

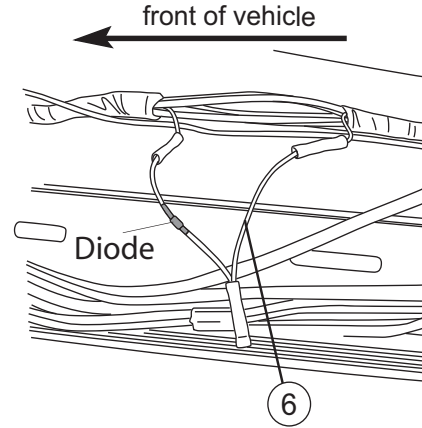

19

20

Connect Double Diode Harness to purple trigger wire and extend each end to the blue butt connectors of steps 19 and 20.

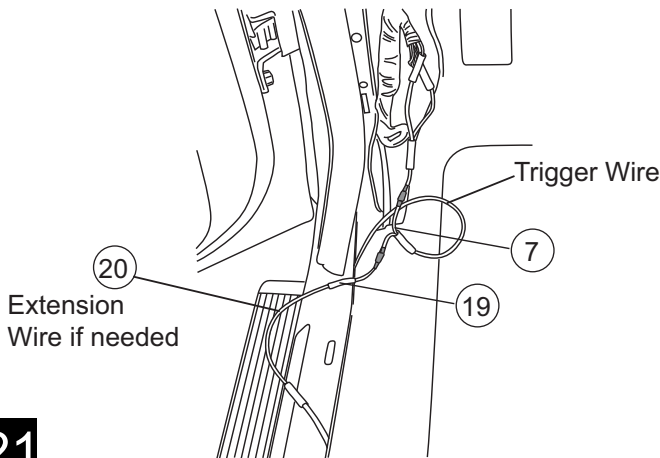

On the Passenger side remove front door paneling and locate wire bundle running out toward the door latch as shown. Connect Single Diode Harness to Black with Pink stripe wire with diode end heading back toward the vehicle cabin.

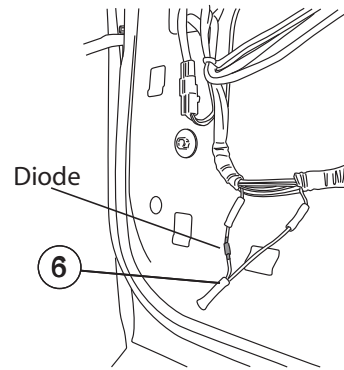

21

22

Pass supplied red connecting wire from door to cabin through the door hinge wire accordion. You may want to use the supplied plastic tubing to help pass the wire through.

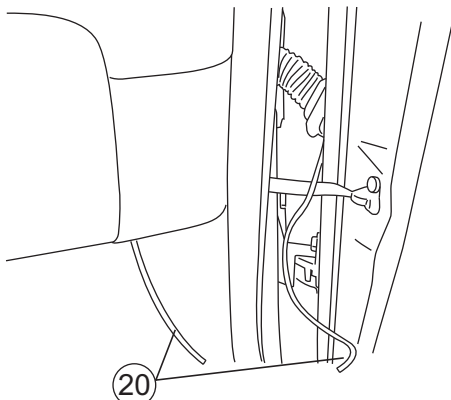

Connect door end of red connecting wire to the blue butt connector of step 22. Secure any loose wires with tie wraps and/or electrical tape.

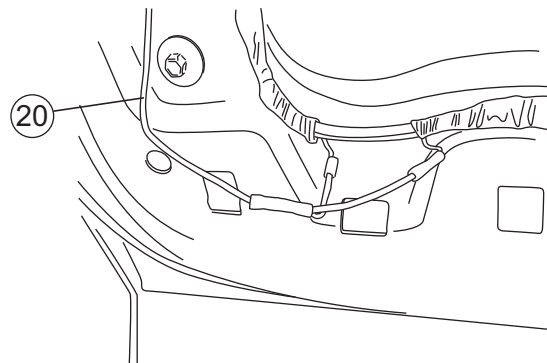

23

24

Under passenger front kick panel locate bundle that comes from the rear of the vehicle. Open the bundle and locate the Black with White stripe wire and splice in Single Diode Harness with the diode end toward the front of the vehicle.

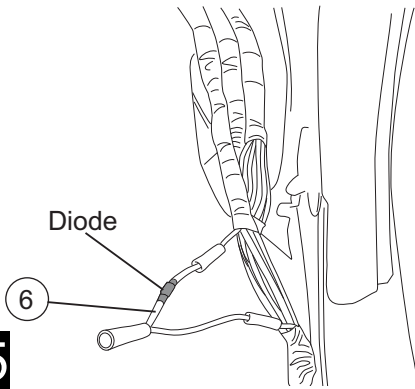

25

Connect purple trigger wire to Double Diode Harness. Connect one open end of the harness to the red connecting wire from the door and the other end to the blue butt connector of step 25.

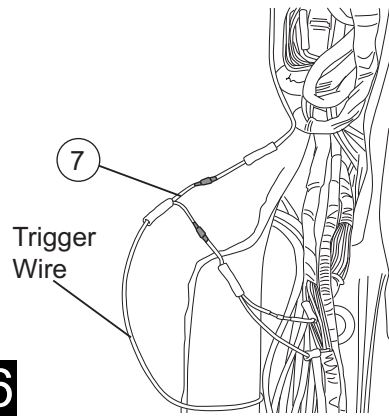

26

Check that all doors activate the Power Step and the LED Lights work when doors open and close. Reinstall any remaining trim panels.

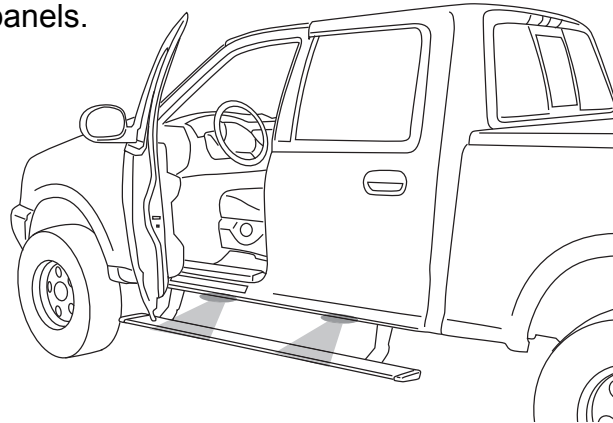

27

Correct operation of Lights: All four lamps will illuminate upon opening any door of vehicle. Lamps will stay on until restowing of both Power Steps or until 5 minutes has expired with the doors open. When the lights timeout after 5 minutes, they can be reilluminated by closing and opening any door of vehicle.

Slight adjustments to the upper mount can be made to adjust stow position. With the board extended, loosen hex bolt as shown, adjust as needed, and retighten hex bolt to 16 ft-lbs. The adjustments will be made to either increase or decrease the gap between the board and rocker panel when stowed.

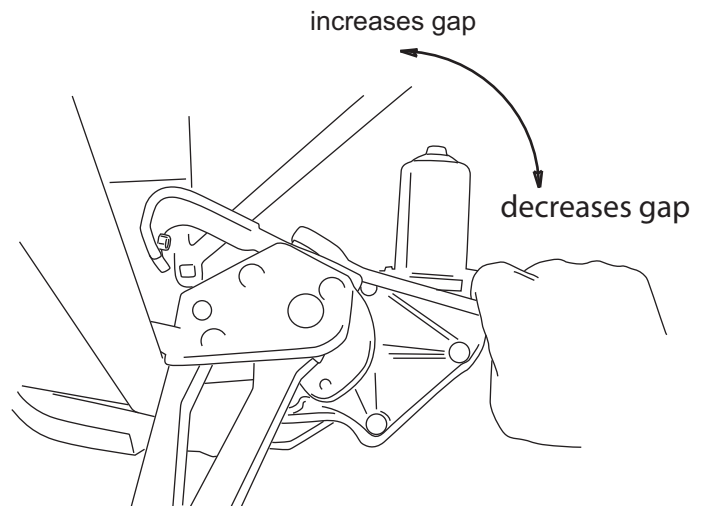

28



Congratulations on your purchase of the genuine AMP Research PowerStep! Here's what you should know...

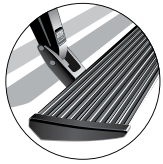

POWERSTEP™ OPERATION - The AMP Research PowerStep™ automatically deploys when any door is opened. When both front and rear doors are closed, it retracts automatically under your vehicle.

The drive system is designed to automatically stop if resistance, blockage or icing occurs. To reset, clear any obstruction, then simply open and close the door and normal operation will resume.

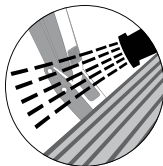

MAINTENANCE TIPS - The stepping surface and linkages should be periodically washed with mild soap and water using a soft brush or sponge to dislodge any mud, dirt or accumulated road grime.

In severe driving conditions, pressure washing the linkages is strongly recommended. Avoid spraying the motors directly with high-pressure water. After washing, apply Silicone spray lubricant to the pivot pins of each linkage assembly. Remove any excess lubricant with a soft clean cloth. Do not apply Silicone spray, waxes or protectants like Armor All® to the stepping surfaces.



KEEPING POWERSTEP™ DEPLOYED - When washing your vehicle, the PowerStep can be set to remain in the deployed position with the doors closed. **DO THIS...**

1. With the PowerStep deployed, firmly press and hold the step down with your foot.
2. Close the door while continuing to press down on the step. *(This will not harm the motor.)*
3. To resume normal operation, simply open and close the door. *(Repeat for both sides of the vehicle.)*

CAUTION! KEEP HANDS AWAY WHEN THE POWERSTEP IS IN MOTION

AMP RESEARCH LIMITED WARRANTY

AMP RESEARCH warrants this product to be free from defects in material and workmanship for FIVE (5) YEARS FROM DATE OF PURCHASE, provided there has been normal use and proper maintenance. This warranty applies to the original purchaser only. All remedies under this warranty are limited to the repair replacement of the product itself, or the repair or replacement of any component part thereof, found by the factory to be defective within the time period specified. The decision to repair or replace is wholly within the discretion of the manufacturer.

This warranty specifically excludes labor. If you have a warranty claim, first you must call our factory at the number below for instructions. You must retain proof of purchase and submit a copy with any items returned for warranty work. Upon completion of warranty work, if any, we will return the repaired or replaced item or items to you freight prepaid. Damage to our products caused by accidents, fire, vandalism, negligence, misinstallation, misuse, Acts of God, or by defective parts not manufactured by us, is not covered under this warranty.

ANY IMPLIED WARRANTIES OF MERCHANTABILITY AND/OR FITNESS FOR A PARTICULAR PURPOSE CREATED HEREBY ARE LIMITED IN DURATION TO THE SAME DURATION AND SCOPE AS THE EXPRESS WRITTEN WARRANTY. OUR COMPANY SHALL NOT BE LIABLE FOR ANY INCIDENTAL OR CONSEQUENTIAL DAMAGE.

Some states do not allow limitations on how long an implied warranty lasts, or the exclusion or limitation of incidental or consequential damages, so the above limitations or exclusions may not apply to you. This warranty gives you specific legal rights, and you may also have other rights that vary from state to state.

FOR WARRANTY ISSUES WITH THIS PRODUCT PLEASE CALL AMP RESEARCH CUSTOMER SERVICE 1-800-315-9697

WARNING

Be sure to read and precisely follow the provided instructions when installing this product. Failure to do so could place the vehicle occupants in a potentially dangerous situation. After installing or reinstalling, re-check to insure that the product is properly installed.