

**AMP**  
RESEARCH **Power Step**  
MADE IN USA

APPLICATION

AMP Part #

Jeep Wrangler Unlimited (JK) 2007–up  
2-Door

75121-01A

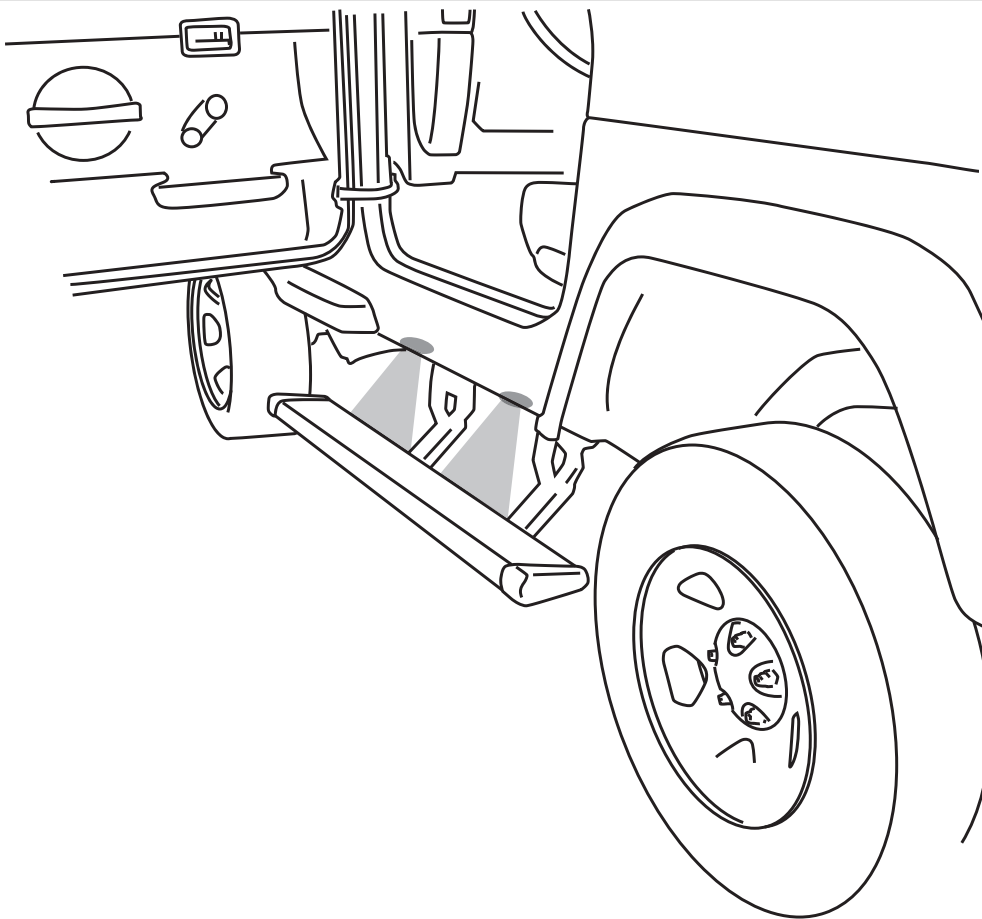

INSTALLATION TIME

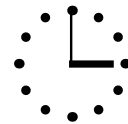

3:00 hrs

SKILL LEVEL



4= Experienced

TOOLS REQUIRED

- 13 mm socket
- 13 mm end wrench
- Ratchet wrench and extension
- Wire crimpers
- Wire stripper/cutter
- 3/16" hex key wrench (allen wrench )
- 4 mm hex key wrench (allen wrench )
- 5 mm hex key wrench (allen wrench )

AMP RESEARCH TECH SUPPORT 1-888-983-2204 (Press 2) Monday - Friday, 6:00 AM - 5:00 PM PST

Designed and manufactured by AMP Research®. Patent Number 6,830,257; 6,641,158; 6,834,875; 6,938,909; 6,942,233; 7,007,961; 7,055,839; 7,163,221; 7,367,574; 7,380,807; 7,398,985; 7,413,204; 7,487,986; 7,566,064; 7,584,975. Other US and Worldwide patents pending. Made in USA  
© 2010 AMP Research. 5-year limited warranty. Professional installation is recommended.

## PARTS LIST AND HARDWARE IDENTIFICATION

19-03199-11 End cap left (x1)  
19-03199-12 End cap right (x1)  
19-02663-90 T-nut insert (x2)  
19-03236-90 Socket cap screw (x2)  
19-03237-90 Nut plate (x2)

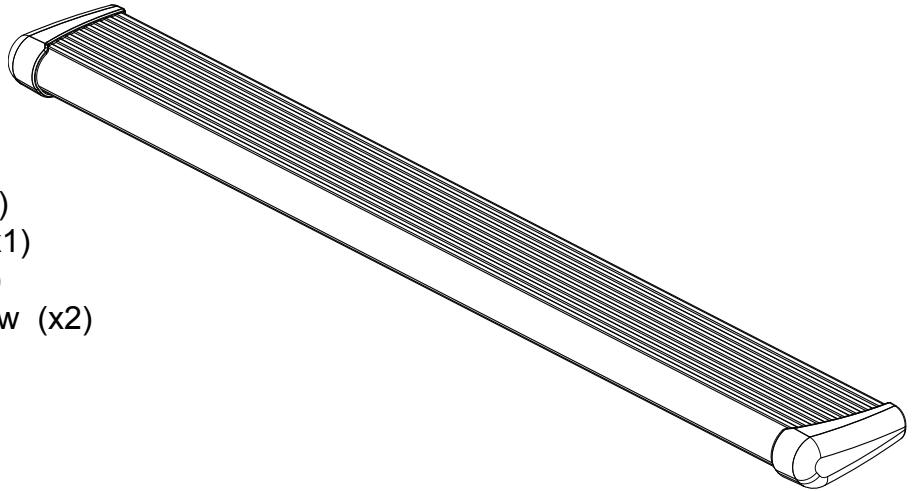

**1** x2 20-03318-48  
Step assembly

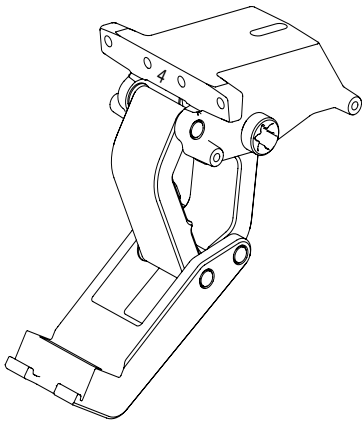

**2** x2  
10-03606-20 Driver (2 door)  
10-03606-21 Passenger (2 door)  
Motor Linkage

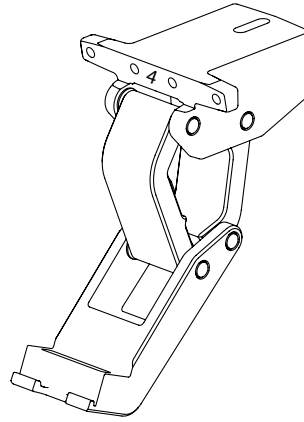

**3** x2  
10-03610-20 (2 door)  
Idler Linkage

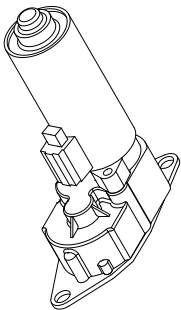

**4** x2  
19-03289-91  
Motor

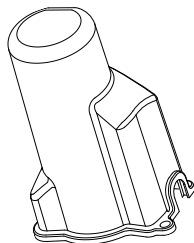

**5** x2  
19-03238-90  
Motor Cover

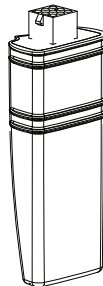

**6**  
19-03297-93  
Controller

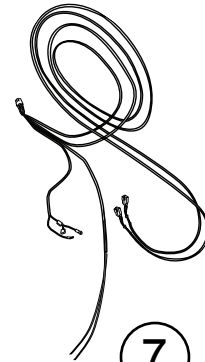

**7**  
19-03717-90L  
Wire Harness

AMP RESEARCH POWER STEP – JEEP WRANGLER (JK)

PARTS LIST AND  
HARDWARE  
IDENTIFICATION



**8** x4  
19-03467-90  
U nut



**9** x8  
19-02802-90  
Socket Cap

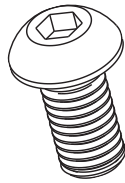

**10** x8  
16-02634-90  
Button Head Bolt



**11** x4  
19-02740-90  
Hex Flange Bolt

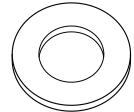

**12** x8  
16-03014-90  
Washer Black



**13** x4  
19-03354-90  
Posi-Taps™ (Red/Grey)



**14** x6  
19-02721-90  
Cinch Fastener

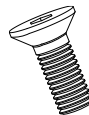

**15** x4  
19-03352 -90  
Flat Head  
Cap Screw



**16** x20  
19-02805-90  
Cable Tie 6"

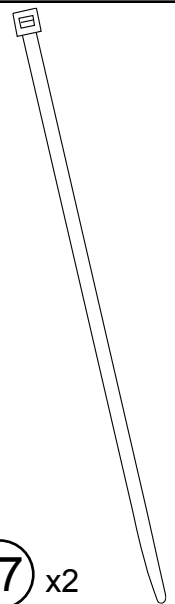

**17** x2  
19-03339-90  
Cable Tie 11"

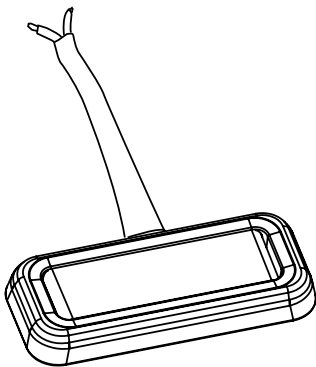

**18** x4  
19-03302-90  
LED Lamp

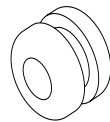

**19** x4  
19-02640-90  
Grommet

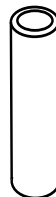

**20** x8  
19-02989-90  
Butt Connector

AMP RESEARCH POWER STEP – JEEP WRANGLER (JK)

Slide motor assembly onto drive shaft and mounting bosses of driving linkage assembly. Use flathead socket head cap screws (16) and tighten to 8 ft-lbs / 11Nm. **Motor faces to front of vehicle**

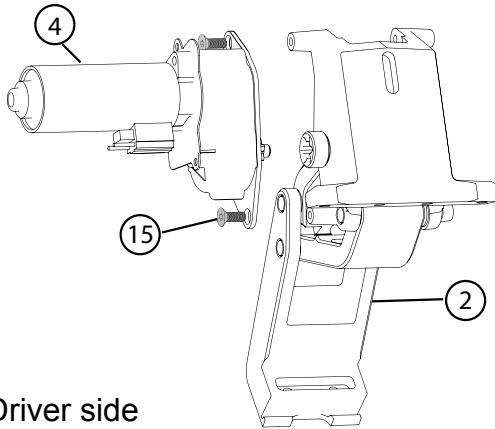

1 Driver side Motor Linkage

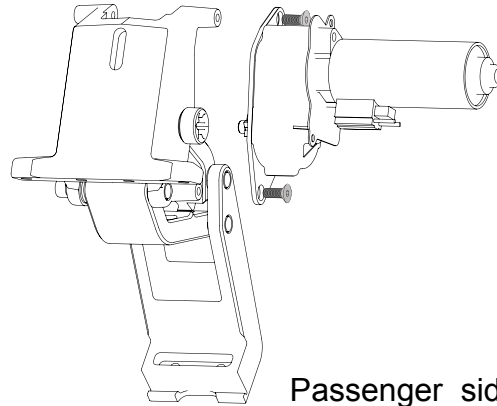

2 Passenger side Motor Linkage

Insert U nut into position for rear Drive Linkage mounting position.

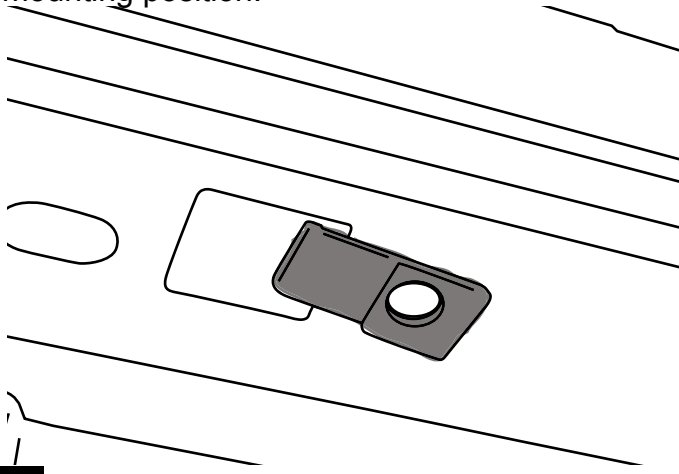

3 Front of vehicle passenger side

Install Rear Drive Linkage assembly. Use button head bolts with washers and Hex flange bolt Torque to 16 ft-lbs. (22N m)

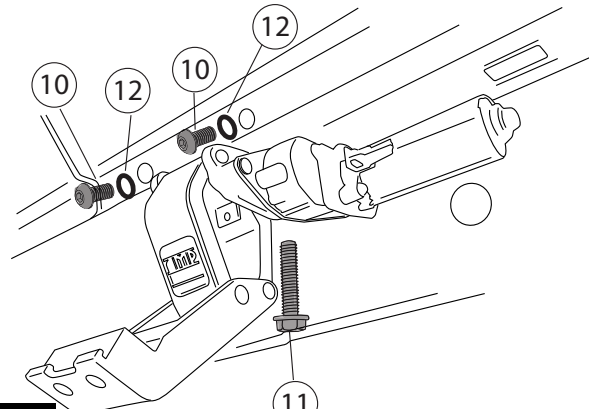

4 Front of vehicle passenger side

Insert U nut into position for front Idler Linkage mounting position.

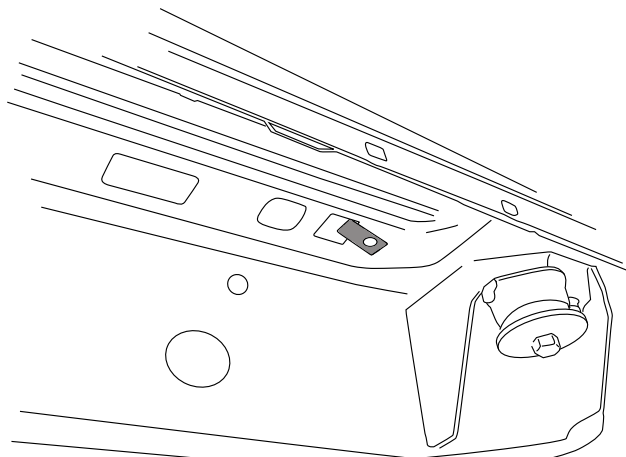

5 Front of vehicle passenger side

Install Front Idler Linkage assembly. Use button head bolts with washers and Hex flange bolt Torque to 16 ft-lbs. (22N m)

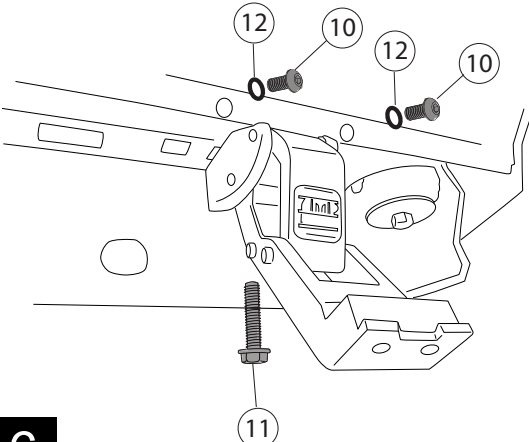

6 Repeat linkage installation on driver side

Mount step extrusion to linkage assemblies. Line up t-nuts in step assembly with slots in lower mounts of linkage assemblies. Fasten loosely to allow for adjustments.

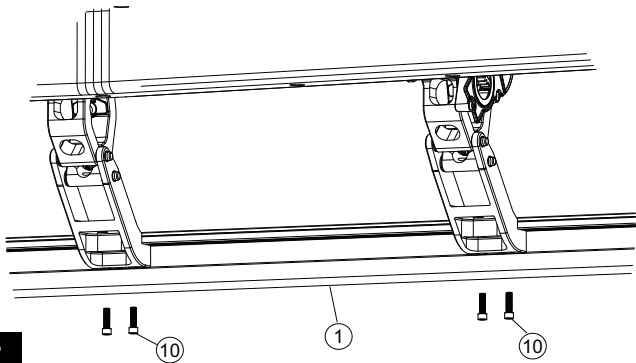

7

Line up rear of step extrusion with rear fender well.

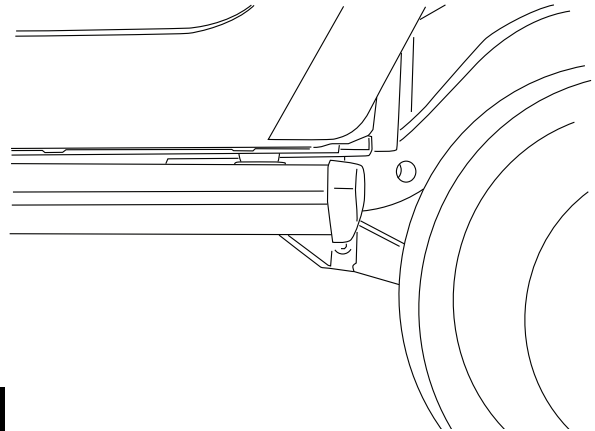

8

Tighten 4 socket cap screws with 3/16" allen wrenr Torque to 10 ft-lbs. (13.5 N-m)

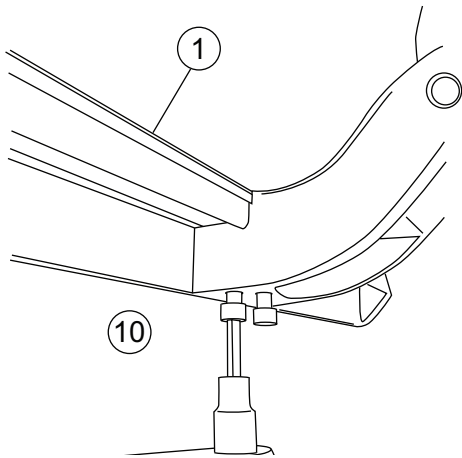

9

Remove fuse from Power Step wire harness.

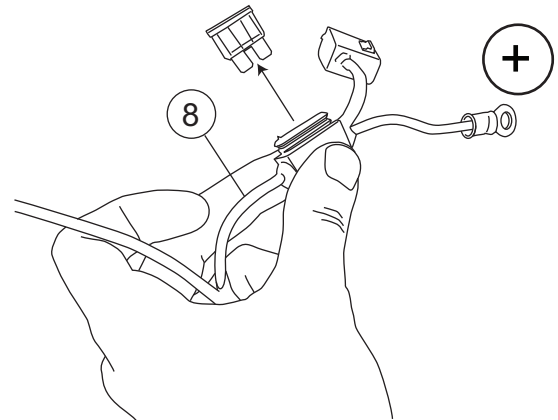

10

Install controller on passenger side at firewall. Secure with 11" cable ties. Connect Red wire to positive battery terminal and Black wire to negative battery terminal.

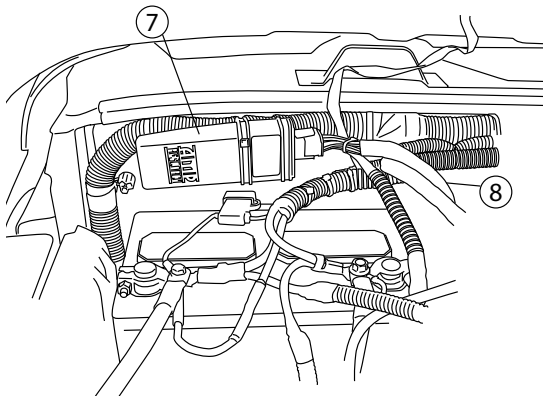

11

Route longest leg of wire harness across fire wall to driver side and under vehicle outside of frame rail. Route shortest leg of wire harness down fire wall and outside of frame rail on passenger side.

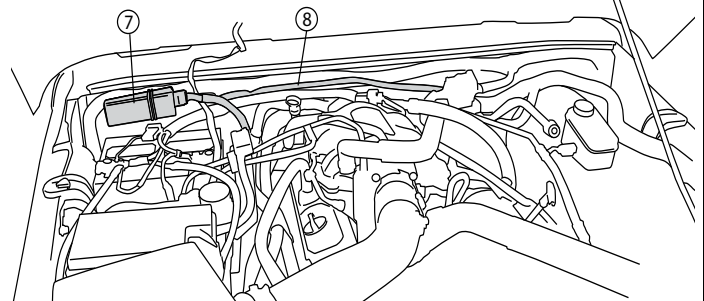

12

Remove passenger side front door sill.

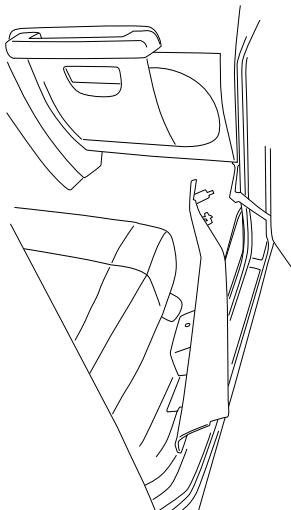

Posi-Tap™ instructions

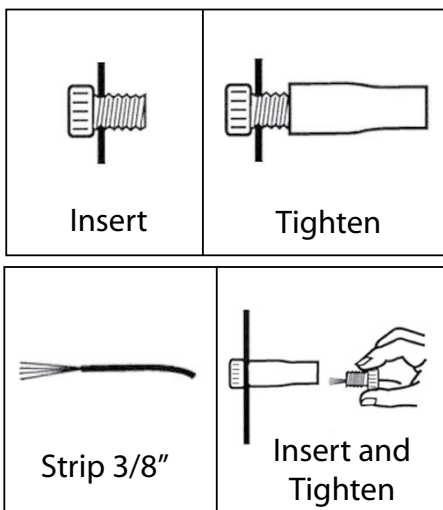

Remove driver side door sill and pull up carpet.

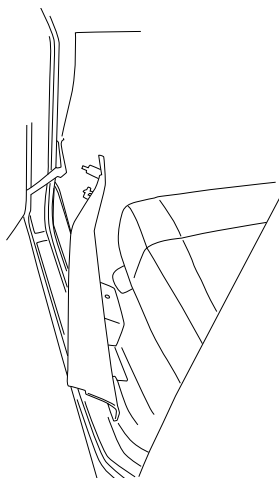

Lift carpet. Slit rubber grommet and pass trigger wires through grommet in floor into passenger compartment.

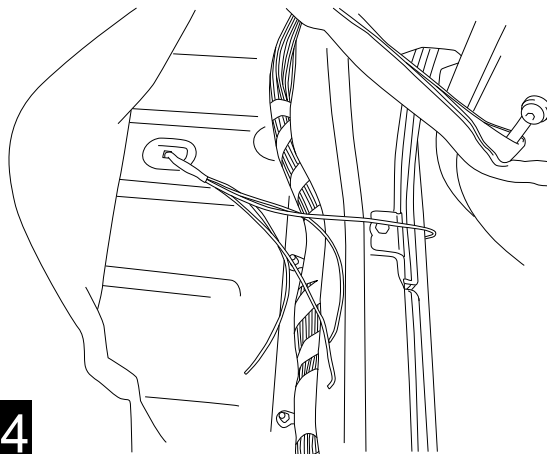

14

Use Posi-Tap connectors to connect Power Step trigger wires to like colored wires in the factory system as shown: Violet/White wire in loom coming from front door, Violet/Yellow and Violet/Grey are not used tape off ends.

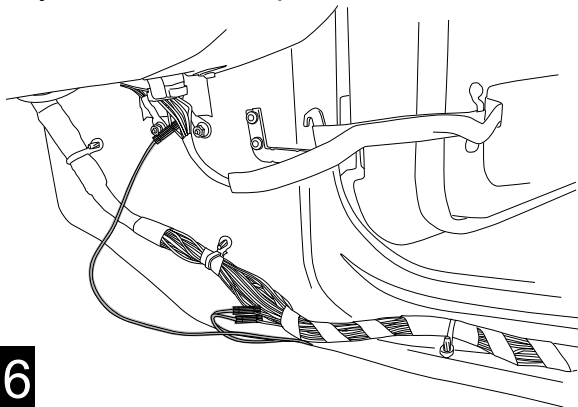

16

Route Violet wire under carpet to driver side door sill and connect to violet wire coming from door as shown.

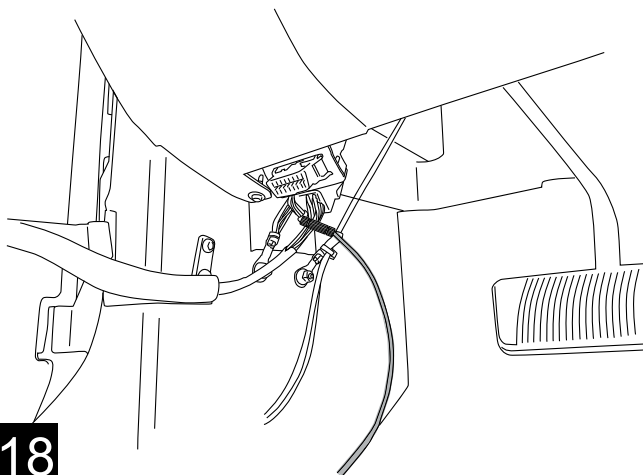

18

17

AMP RESEARCH POWER STEP – JEEP WRANGLER (JK)

Insert plug from wire harness onto motor. Slide rubber grommet on wire harness into slot of motor cover. Insert motor cover onto motor. Slide motor assembly onto drive shaft and mounting bosses of driving linkage assembly. Use electrical tape to cover any exposed wire from the motor.

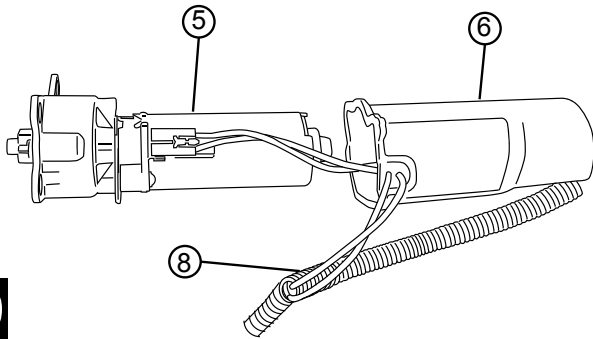

19

Insert plastic push pin rivets in mounting holes of motor cover. Use pliers to ease installation.

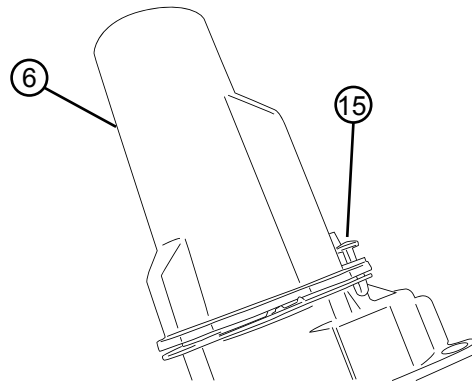

20

On each side of the vehicle install LED Lamps to the rear of both linkages.

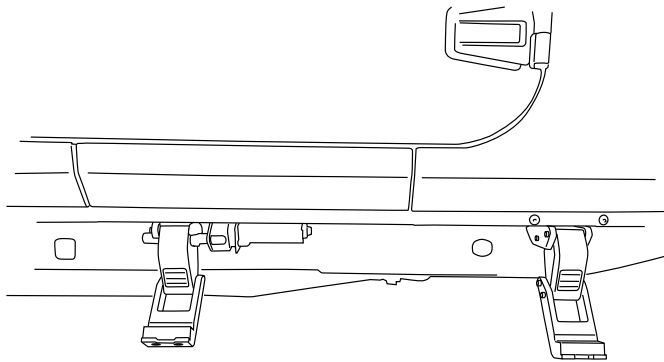

21

Using supplied butt connectors, connect the lamp wires. Red to Red, Black to Black.

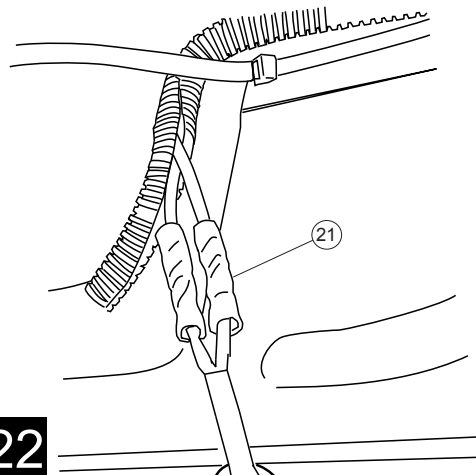

22

Close and wrap with conduit and electrical tape. Secure all loose wires with cable ties, with lamp wires pulled upward to avoid any wire snagging.

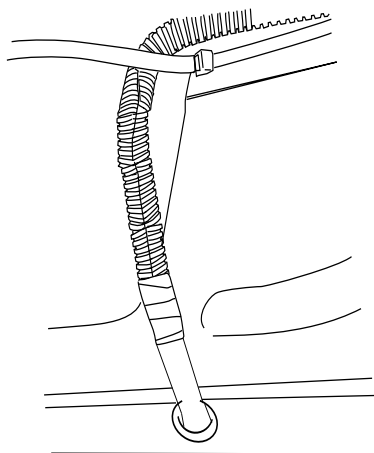

23

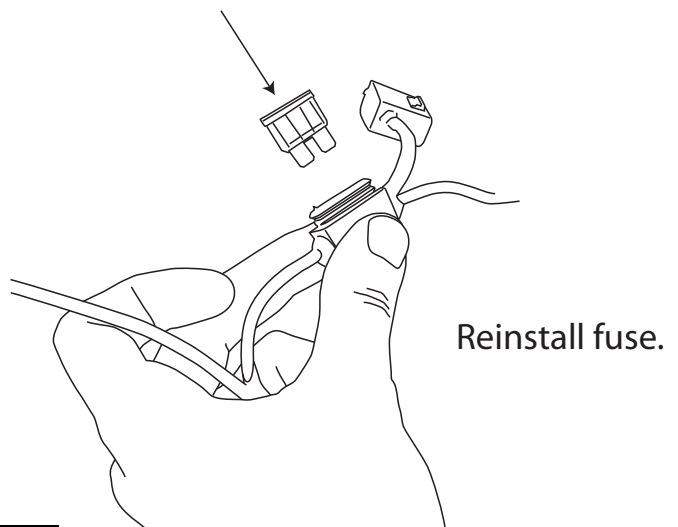

24

Check that all doors activate the Power Step and the LED Lights work when doors open and close. Reinstall any remaining trim panels.

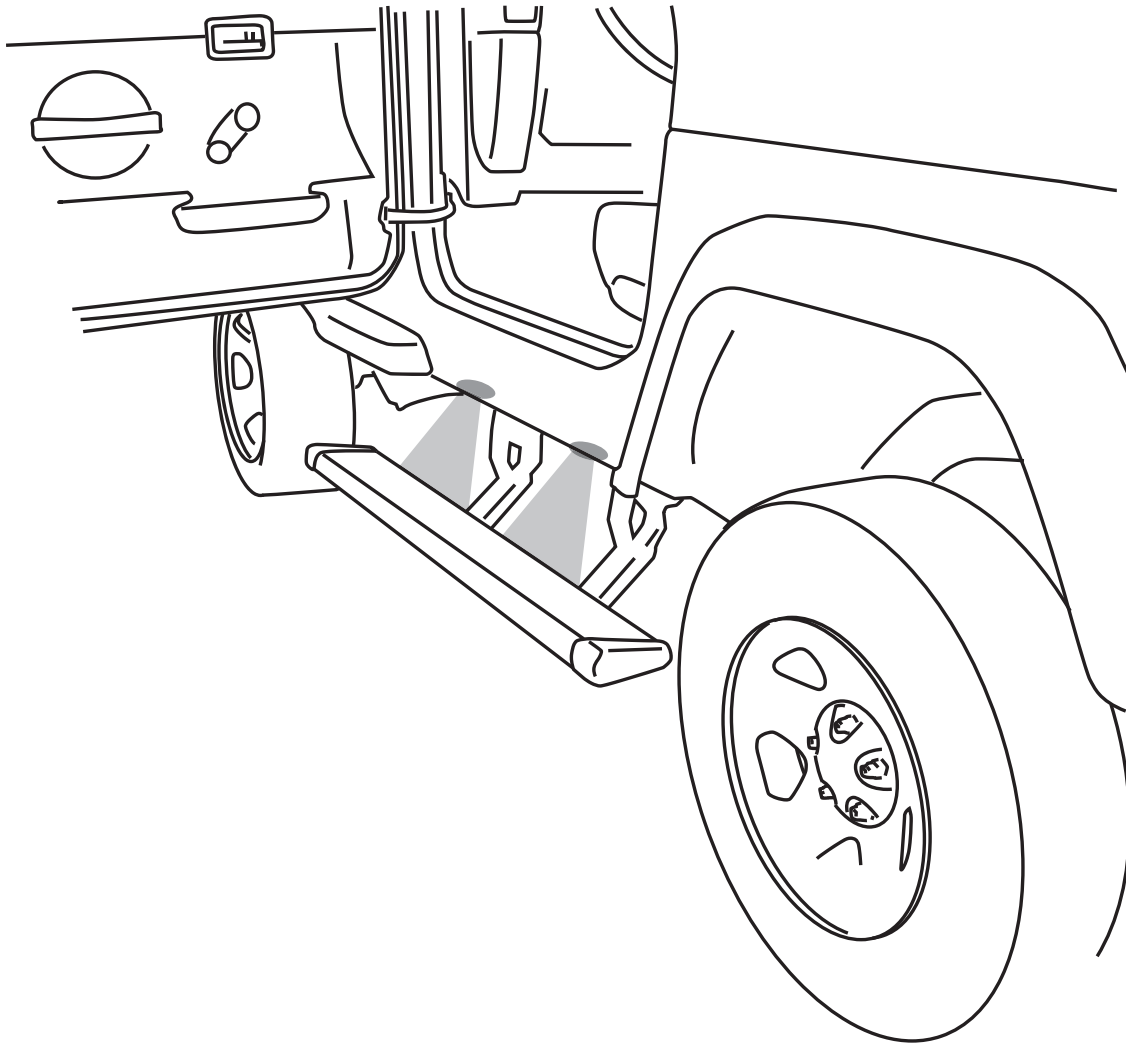

**Correct operation of Lights:** All four lamps will illuminate upon opening any door of vehicle. Lamps will stay on until restowing of both Power Steps or until 5 minutes has expired with the doors open. When the lights timeout after 5 minutes, they can be re-illuminated by closing and opening of any door of vehicle.



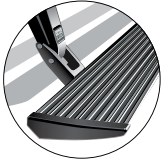

**POWERSTEP™ OPERATION** - The AMP Research PowerStep™ automatically deploys when any door is opened. When both front and rear doors are closed, it retracts automatically under your vehicle.

**The drive system is designed to automatically stop if resistance, blockage or icing occurs.** To reset, clear any obstruction, then simply open and close the door and normal operation will resume.

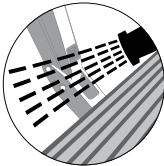

**MAINTENANCE TIPS** - The stepping surface and linkages should be periodically washed with mild soap and water using a soft brush or sponge to dislodge any mud, dirt or accumulated road grime.

**In severe driving conditions, pressure washing the linkages is strongly recommended.**

Avoid spraying the motors directly with high-pressure water. After washing, apply Silicone spray lubricant to the pivot pins of each linkage assembly. Remove any excess lubricant with a soft clean cloth. Do not apply Silicone spray, waxes or protectants like Armor All® to the stepping surfaces.



**KEEPING POWERSTEP™ DEPLOYED** - When washing your vehicle, the PowerStep can be set to remain in the deployed position with the doors closed. **DO THIS...**

1. With the PowerStep deployed, firmly press and hold the step down with your foot.
2. Close the door while continuing to press down on the step. *(This will not harm the motor.)*
3. To resume normal operation, simply open and close the door. *(Repeat for both sides of the vehicle.)*

**CAUTION! KEEP HANDS AWAY WHEN THE POWERSTEP IS IN MOTION**

## AMP RESEARCH LIMITED WARRANTY

AMP RESEARCH warrants this product to be free from defects in material and workmanship for FIVE (5) YEARS FROM DATE OF PURCHASE, provided there has been normal use and proper maintenance. This warranty applies to the original purchaser only. All remedies under this warranty are limited to the repair replacement of the product itself, or the repair or replacement of any component part thereof, found by the factory to be defective within the time period specified. The decision to repair or replace is wholly within the discretion of the manufacturer.

This warranty specifically excludes labor. If you have a warranty claim, first you must call our factory at the number below for instructions. You must retain proof of purchase and submit a copy with any items returned for warranty work. Upon completion of warranty work, if any, we will return the repaired or replaced item or items to you freight prepaid. Damage to our products caused by accidents, fire, vandalism, negligence, misinstallation, misuse, Acts of God, or by defective parts not manufactured by us, is not covered under this warranty.

ANY IMPLIED WARRANTIES OF MERCHANTABILITY AND/OR FITNESS FOR A PARTICULAR PURPOSE CREATED HEREBY ARE LIMITED IN DURATION TO THE SAME DURATION AND SCOPE AS THE EXPRESS WRITTEN WARRANTY. OUR COMPANY SHALL NOT BE LIABLE FOR ANY INCIDENTAL OR CONSEQUENTIAL DAMAGE.

Some states do not allow limitations on how long an implied warranty lasts, or the exclusion or limitation of incidental or consequential damages, so the above limitations or exclusions may not apply to you. This warranty gives you specific legal rights, and you may also have other rights that vary from state to state.

**FOR WARRANTY ISSUES WITH THIS PRODUCT PLEASE CALL AMP RESEARCH CUSTOMER SERVICE 1-800-315-9697**

## WARNING

Be sure to read and precisely follow the provided instructions when installing this product. Failure to do so could place the vehicle occupants in a potentially dangerous situation. After installing or reinstalling, re-check to insure that the product is properly installed.