

INSTALLATION GUIDE



Power Step

MADE IN USA



APPLICATION

Ford Bronco 4 Door

MODEL YEAR

2021-2024

AMP Part #

77140-01A

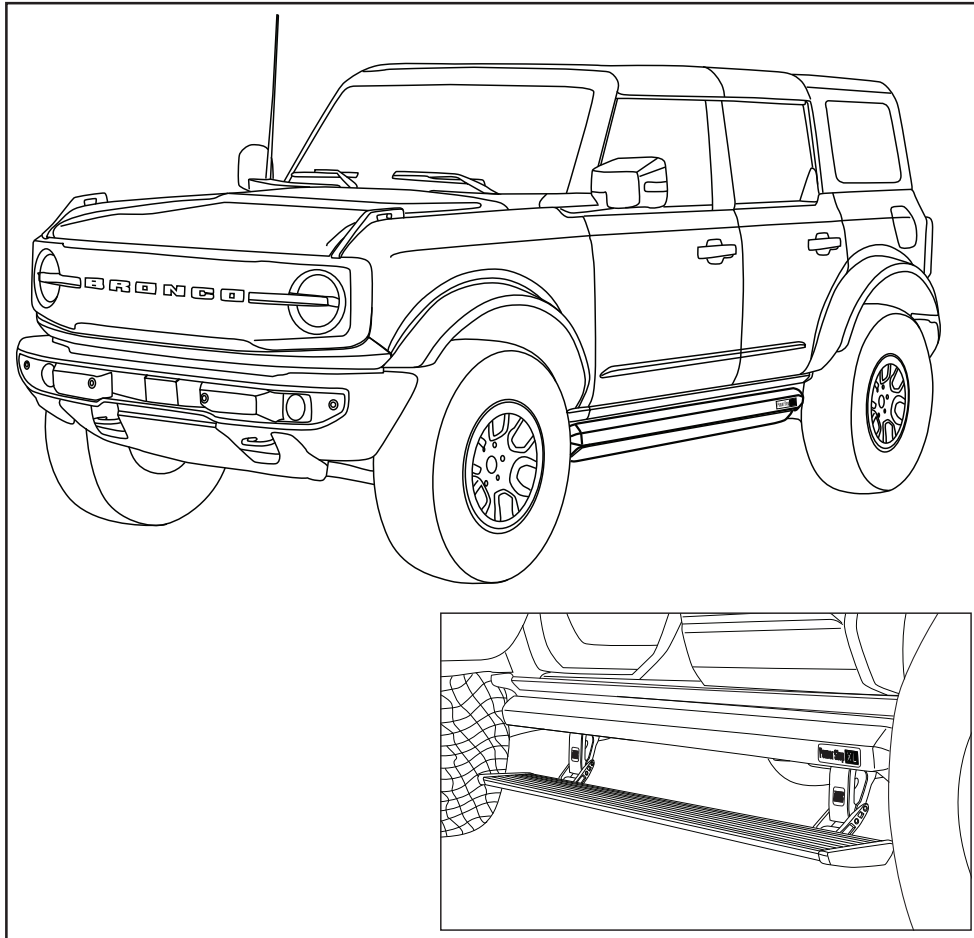

INSTALLATION TIME

3-5 Hours

Professional installation recommended

SKILL LEVEL



4= Experienced

TOOLS REQUIRED

- Safety goggles
- Measuring tape
- 10 mm socket
- 13 mm socket
- 1/2" socket
- Ratchet wrench and extension
- Wire crimpers
- Wire stripper / cutter
- 3/16" hex key wrench (allen wrench)
- 4mm hex key wrench (allen wrench)
- Electrical tape
- Weather proof caulking (silicone sealer)
- Silicone spray
- 5/32" Allen Key

WARRANTY

5-Year Limited Warranty

AMP RESEARCH TECH SUPPORT 1-888-983-2204 (Press 2) Monday - Friday, 7:00 AM - 5:00 PM PST

Invented, engineered and manufactured exclusively by AMP Research in the USA. May be covered by one OR MORE of the following patents: 6,641,158; 6,830,257; 6,834,875; 6,938,909; 7,055,839; 7,380,807; 7,413,204; 7,398,985; 7,584,975; 7,566,064; 7,487,986; 8,157,277; 8,408,571; 9,302,626; 9,561,751; 10,053,017; CA2463717 ©2024 AMP Research. All rights reserved. Printed in USA.

INSTALLATION GUIDE

Attaching motor to Linkage assembly.

EXPLODED VIEW

- Motor
- Socket cap screw
- Washer
- Drive Gear Housing Cover

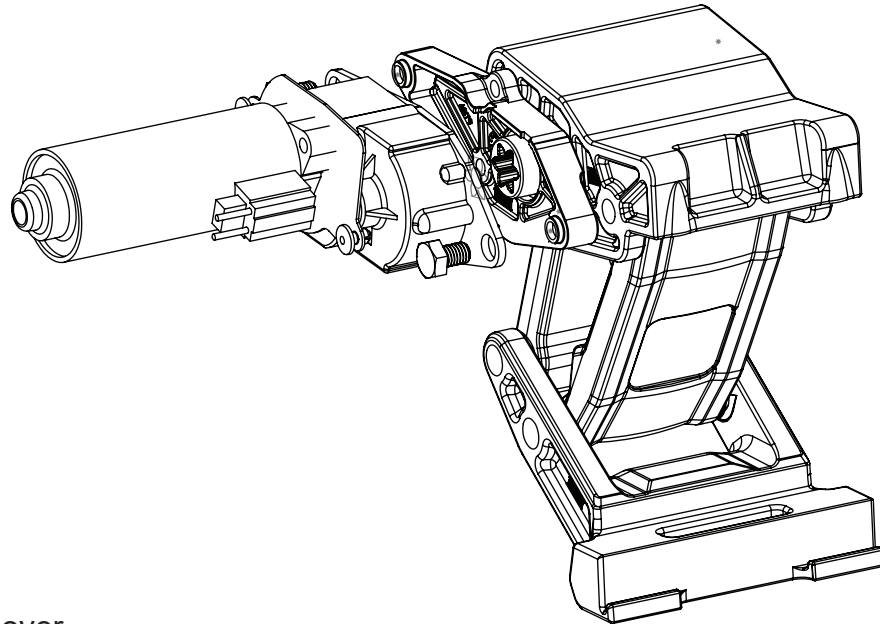
**CAUTION: HANDLE WITH CARE.**

To ensure our customers receive all components with full integrity, we pack the motors separate from their linkage assemblies. This requires that the installer position and fasten the motor before continuing with the install. Please follow the instructions below and handle the assembly carefully.

CAUTION: Dropping the assembly or any excessive impact MAY cause damage to the motor.

Instructions:

1. Position the gear cover in place as shown if not already in place.
2. Seat motor into position on the three mounting bosses. This may require an adjustment of the gear by moving the swing arms.
3. After seating into place, fasten the motor with the three motor mount screws with 4mm Hex Head. Tighten screws to 36 in-lbs (4N-m). **Do not over torque.**

PARTS LIST AND HARDWARE IDENTIFICATION

1

Running Board assembly

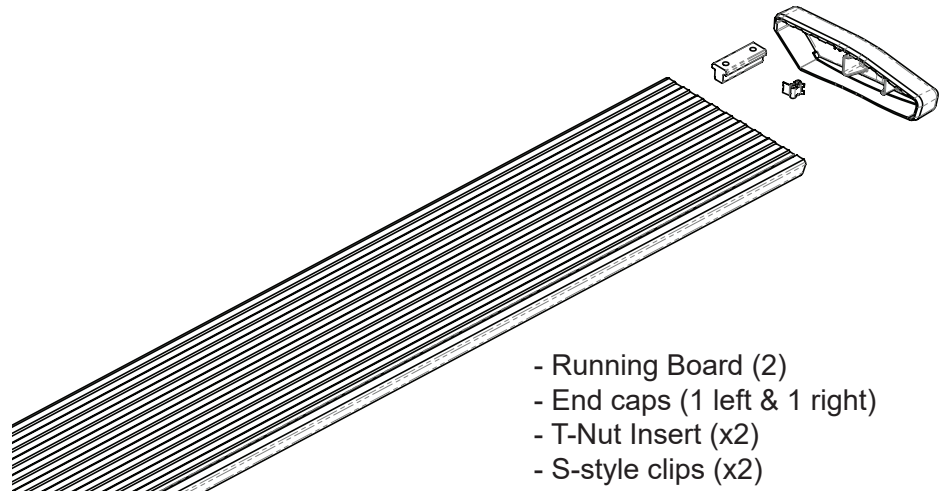

- Running Board (2)
- End caps (1 left & 1 right)
- T-Nut Insert (x2)
- S-style clips (x2)

2 x2

Rail Assembly

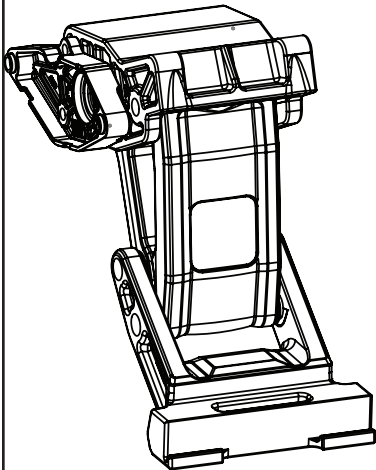
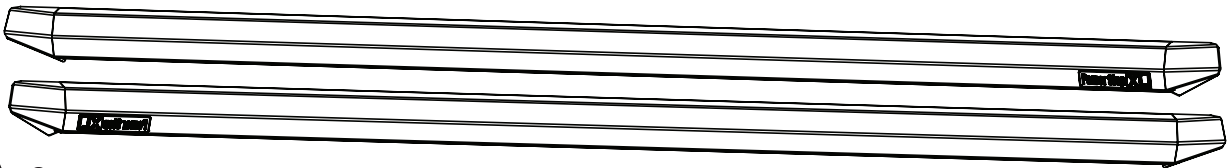

3

Motor Linkage assembly
Driver

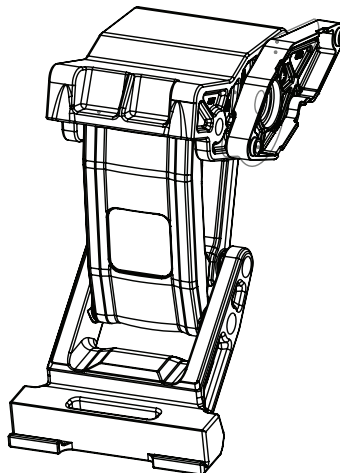

4

Motor Linkage assembly
Passenger

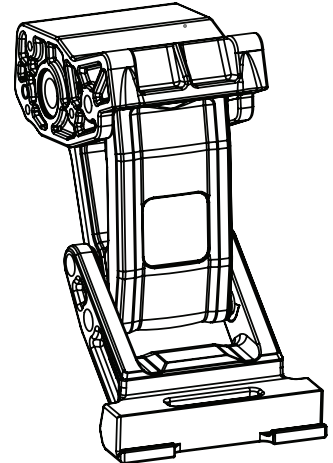

5 x2

Idler Linkage assembly

PARTS LIST AND HARDWARE IDENTIFICATION

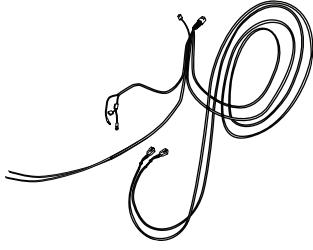

6

Wire harness

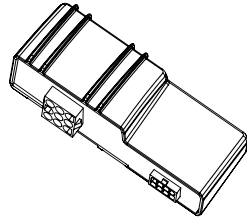

7

Controller STA

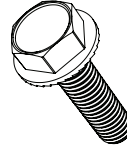

8 x8

M10 Hex Flange Bolt

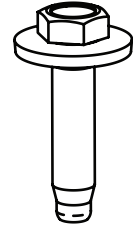

9 x8

M8 Hex Bolt w
Conical washer



10 x4

M6 Flange Bolt



11 x8

Socket Cap Screw

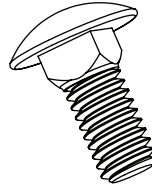

12 x12

5/16-18
Carriage Bolt

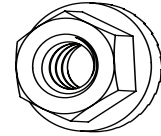

13 x12

5/16-18
Flange nut

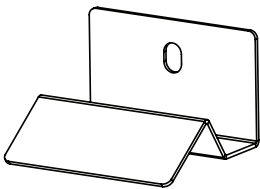

14 x4

LED Light Bracket

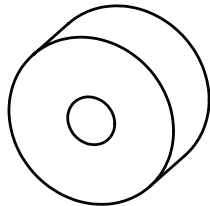

15 x4

Upper Mount
Spacer

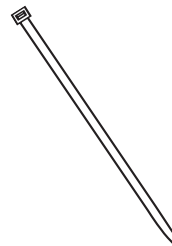

16 x20

Cable tie (7")

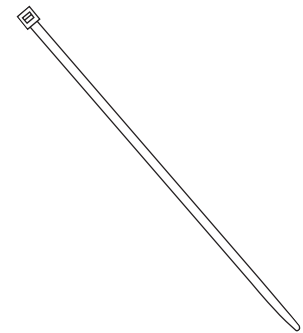

17 x2

Cable tie (11")

AMP RESEARCH POWERSTEP XL™ – FORD BRONCO 4 DOOR
PARTS LIST AND HARDWARE IDENTIFICATION

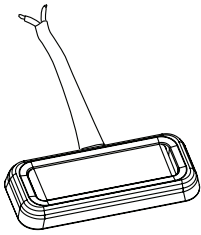

18 x4
LED Lamp

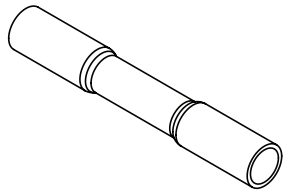

19 x8
Butt Connector

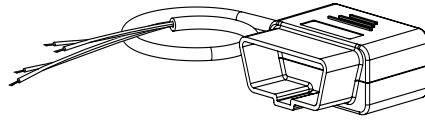

20
ODB II Plug

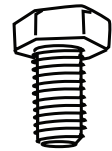

21 x4
M8 Head
Hex Bolt

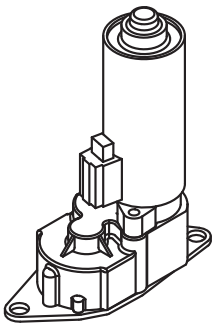

22 x2
Motor

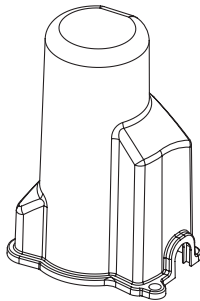

23 x2
Motor Cover



24 x6
Cinch Fastener

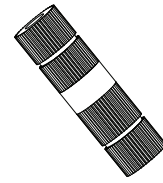

25 x2
Posi-Lock™

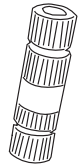

26 x2
Posi-Tap™
(Red)

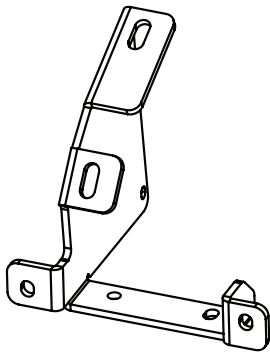

Driver Front

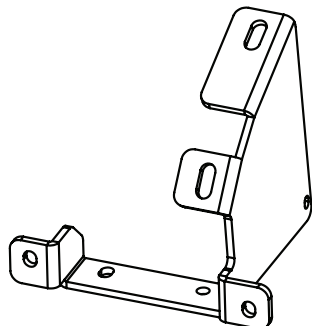

Passenger Front

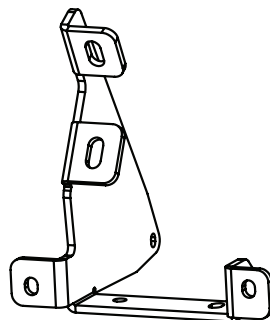

Passenger Rear

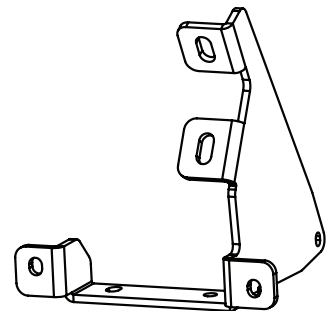

Driver Rear

27
Front Side Brackets

28
Rear Side Brackets

Locate **Front Idler linkage** location. If plastic plugs are present remove plastic plugs to expose threads.

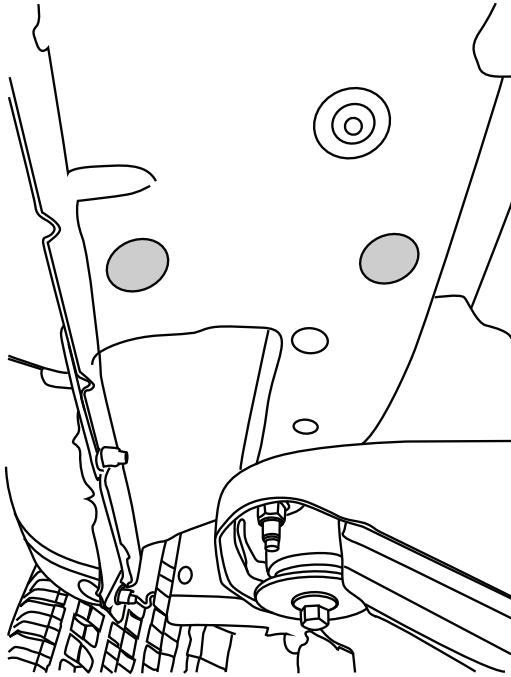

1

Attach bracket (27) using M10 Hex Flange Bolts (8).

Driver side shown.

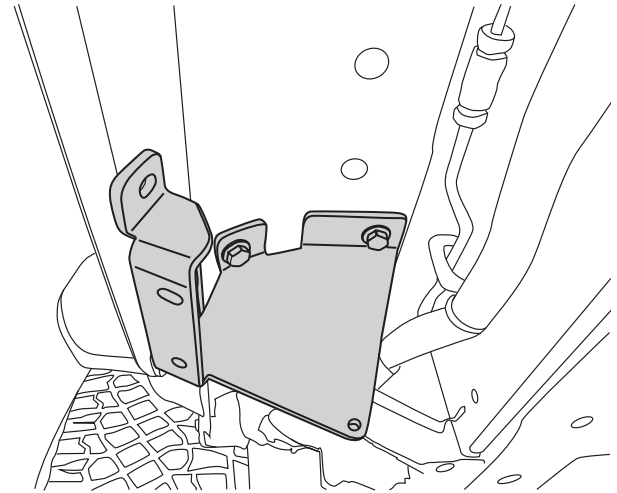

2

Locate **Rear Drive linkage** location. If plastic plugs are present remove plastic plugs to expose threads.

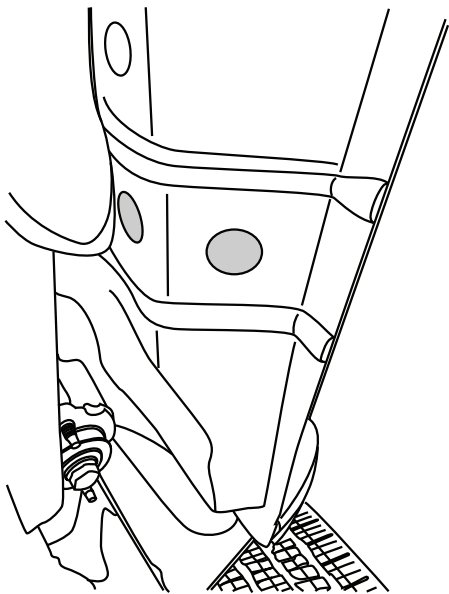

3

Attach bracket (28) using M10 Hex Flange Bolts (8).

Driver side shown.

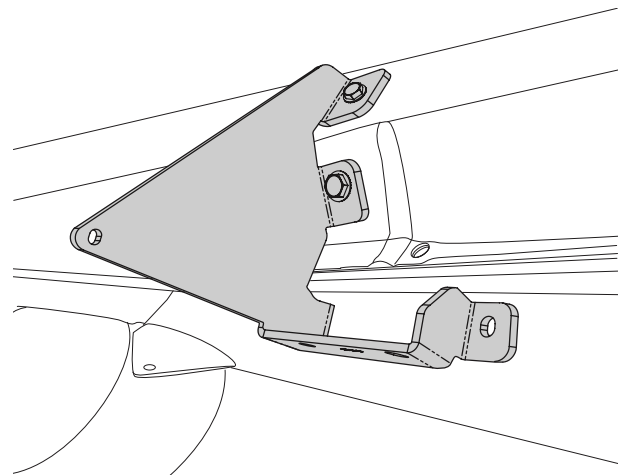

4

AMP RESEARCH POWERSTEP XL™ – FORD BRONCO 4 DOOR

Insert 6 Carriage bolts (#12) into slot on rail (#2) from either end of rail. Add Light Bracket (#14) on the 3rd and 4th bolt. Insert Flange nut (#13) onto bracket tab to attach light brackets (14) into position shown. Dimensions shown are for reference. Leave loose to allow for adjustment.

Driver side shown.

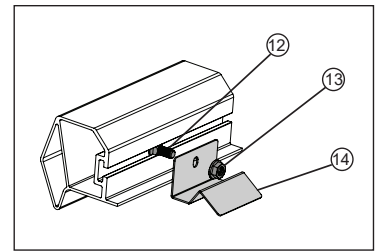
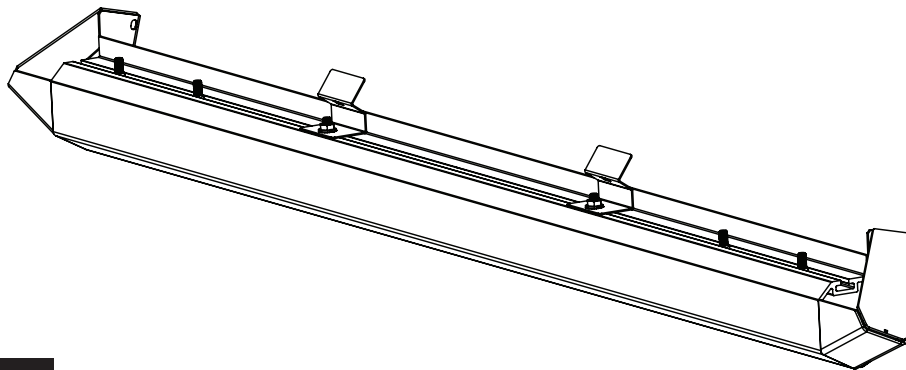

5

Set rail up into position, center in rocker panel area. Starting with the rear bracket, work towards the two front brackets. Insert Flange nut (13) to bolts to attach rail to brackets.

Start from rear of vehicle and torque 4x M10 Flange Nuts (13) to 16 ft-lbs.

Note: DO NOT TORQUE nuts holding light brackets. They will be tightened in step 18.

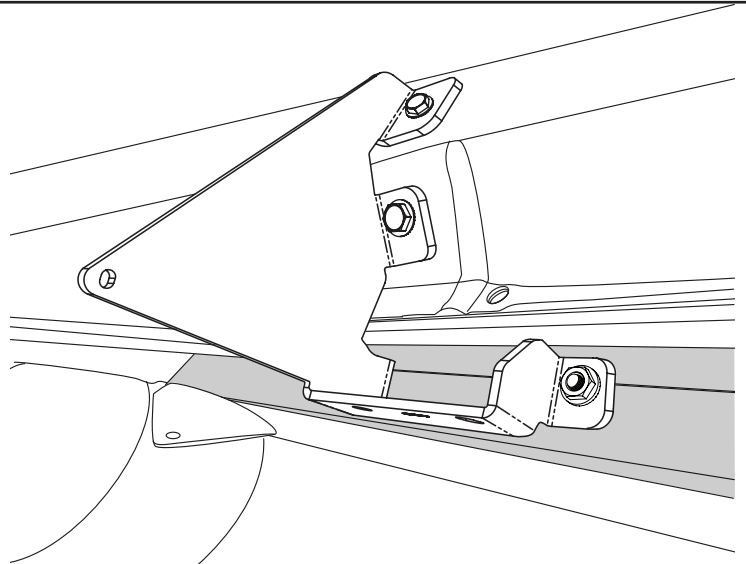

6

Mount front drive linkage onto rear location on driver side. Thread supplied M8 Hex bolts (#9) into front drive linkage. Repeat step for Front idler linkage.

Do not tighten.

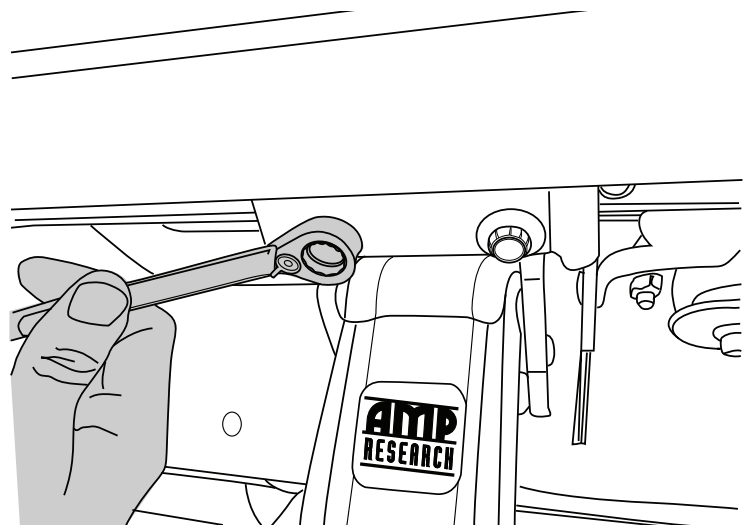

7

Install provided Spacer (15) and M6 Bolt (10) into upper mount as shown on both the Drive and Idler linkages. Do not tighten.

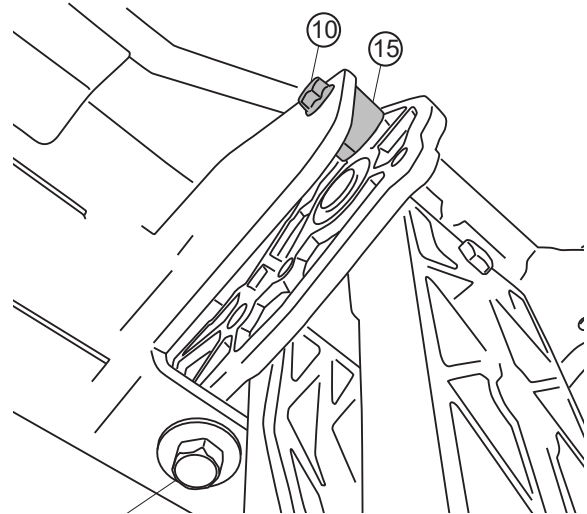

8

Slide mounting T-nut into position, Center board in rail pocket. Tighten Socket Cap screws (11) to 10 ft-lbs.

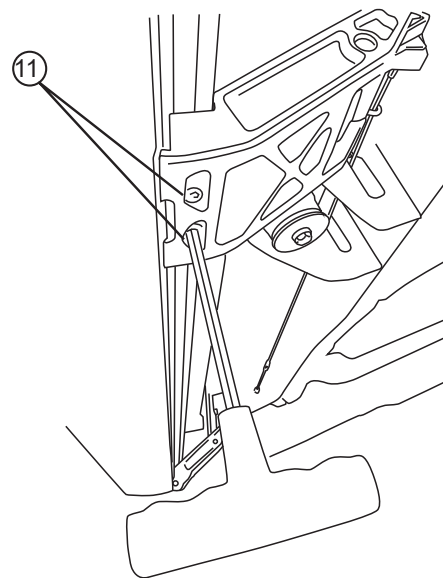
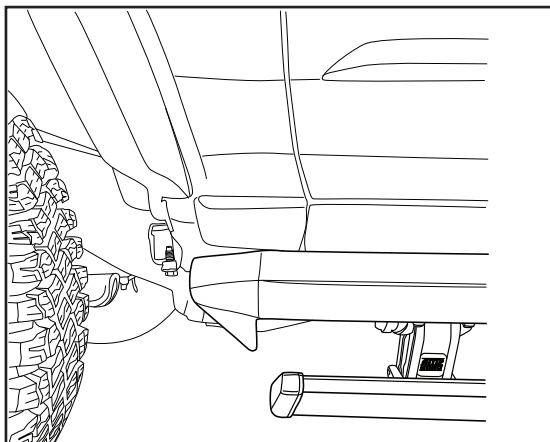

9

Using a 13mm socket Torque linkage bolts 4x (9) from step 5 to 16 ft-lbs. Next use a 10mm socket, torque linkage spacer bolt 2x (11) from step 6 to 8 ft-lbs.

Once linkages are tight cycle board to verify steps deploy under own weight.

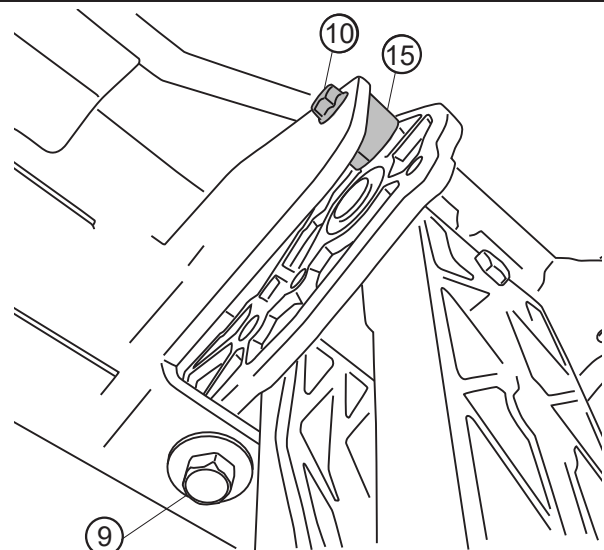

10

AMP RESEARCH POWERSTEP XL™ – FORD BRONCO 4 DOOR

Remove fuses from Power Step Wire Harness (6). Mount controller using supplied zip ties (17) to harness (6) in front of battery as shown. Connect positive leads from harness. Red to positive battery terminal and black to negative battery terminal.

Remove fuses from
Power Step Wire
Harness.

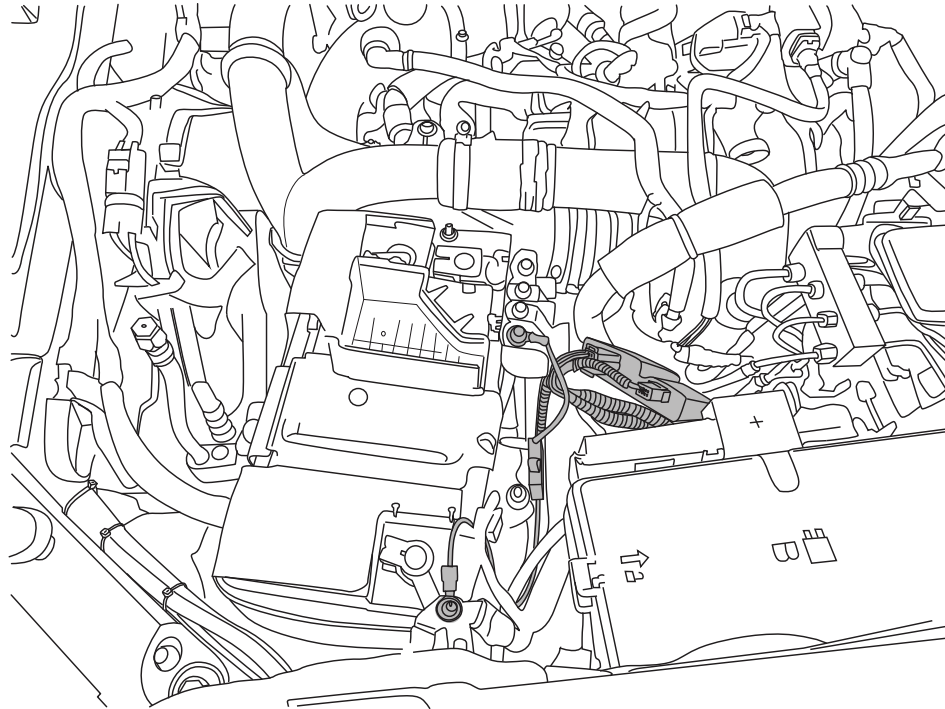
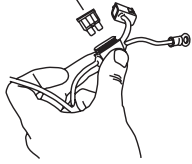

11

Route the two wire harness legs down over to each wheel well. Long leg will run across to passenger side, short leg will run down to driver side. Ensure loom is free from steering and exhaust components. Secure harness with Zip Ties (16).

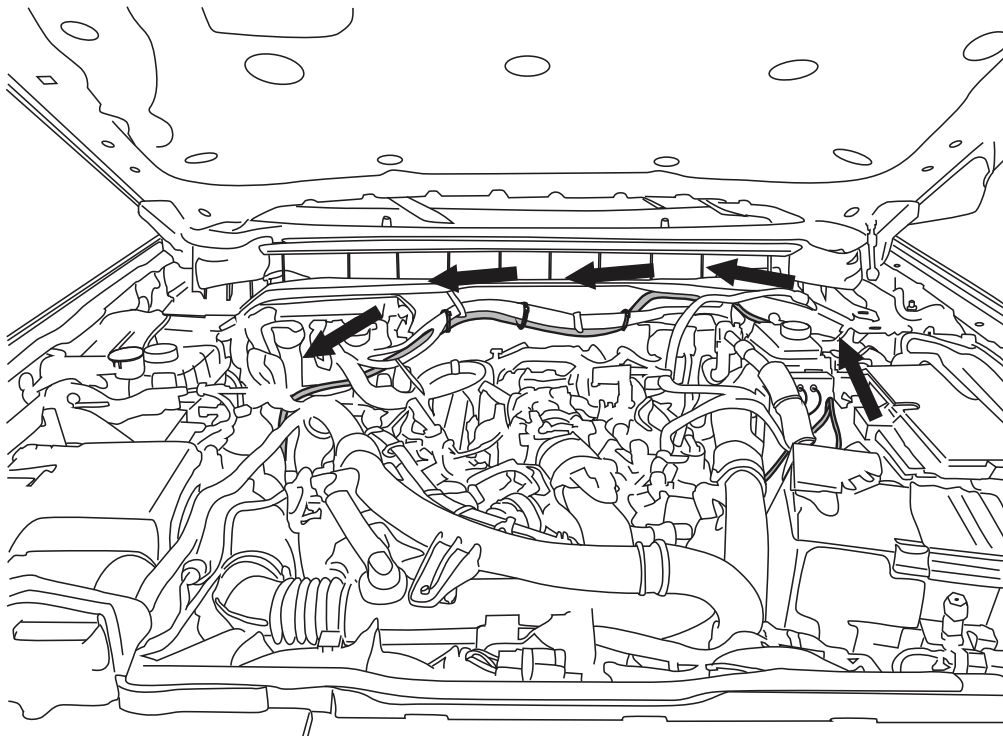

12

Locate oval grommet on driver side of firewall and push out. Poke small hole in grommet and thread trigger wires into cab of vehicle.

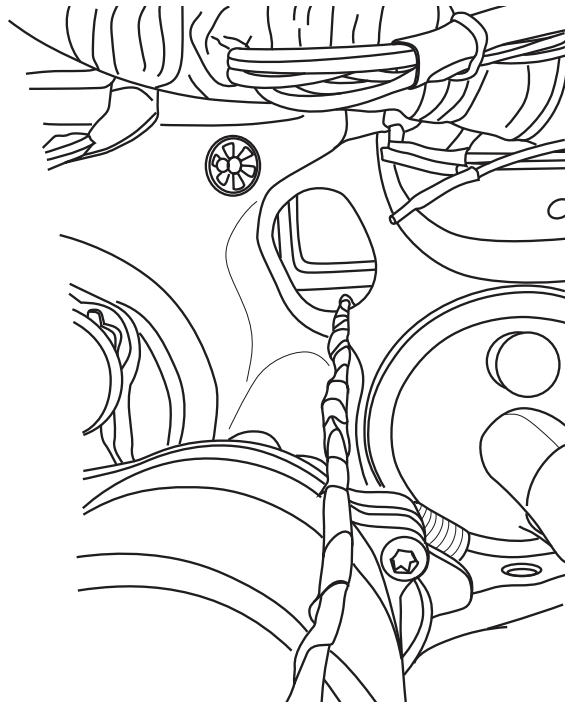

13

Locate the following wires and connect with supplied Posi-Tap™ (26) to the following wire colors listed below.

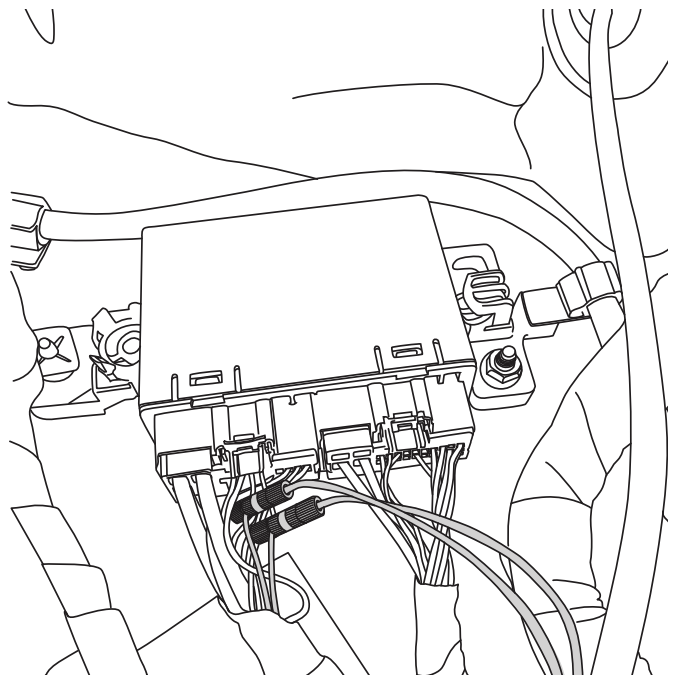

2021-2023

Factory Can Wire	OBD Module Wire Color
Grey with Orange Stripe	White Wire
Purple with Orange Stripe	Blue Wire

2024

Factory Can Wire	OBD Module Wire Color
Green with Orange Stripe	White Wire
Purple with Orange Stripe	Blue Wire

14

Wire OBD II connector with Posi-Lock™ (25)

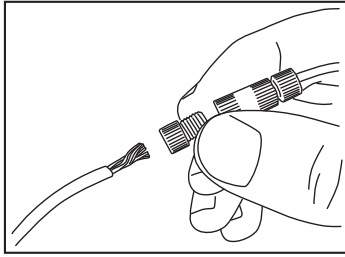

OBD II Connector located below steering column.

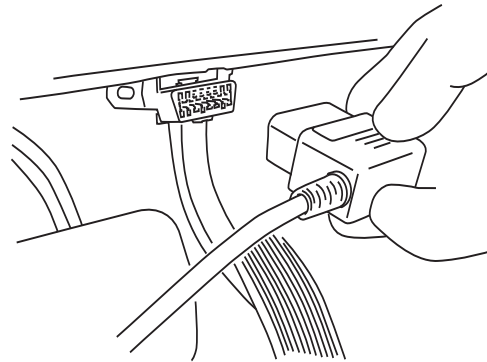

OBD II install: Use Supplied Posi-Lock™ (25) connectors to attach the Plug and Play Module to the Harness. Attach matching colors on the harness to the wires on the module. Plug in module to OBD II port on the vehicle. Secure harness with supplied tie wraps. **Note: If the OBD II pass thru harness (76404-01A) was purchased see install sheet supplied in packaging. The pass through harness allows for an open port for other accessories. See below for a brief description.**

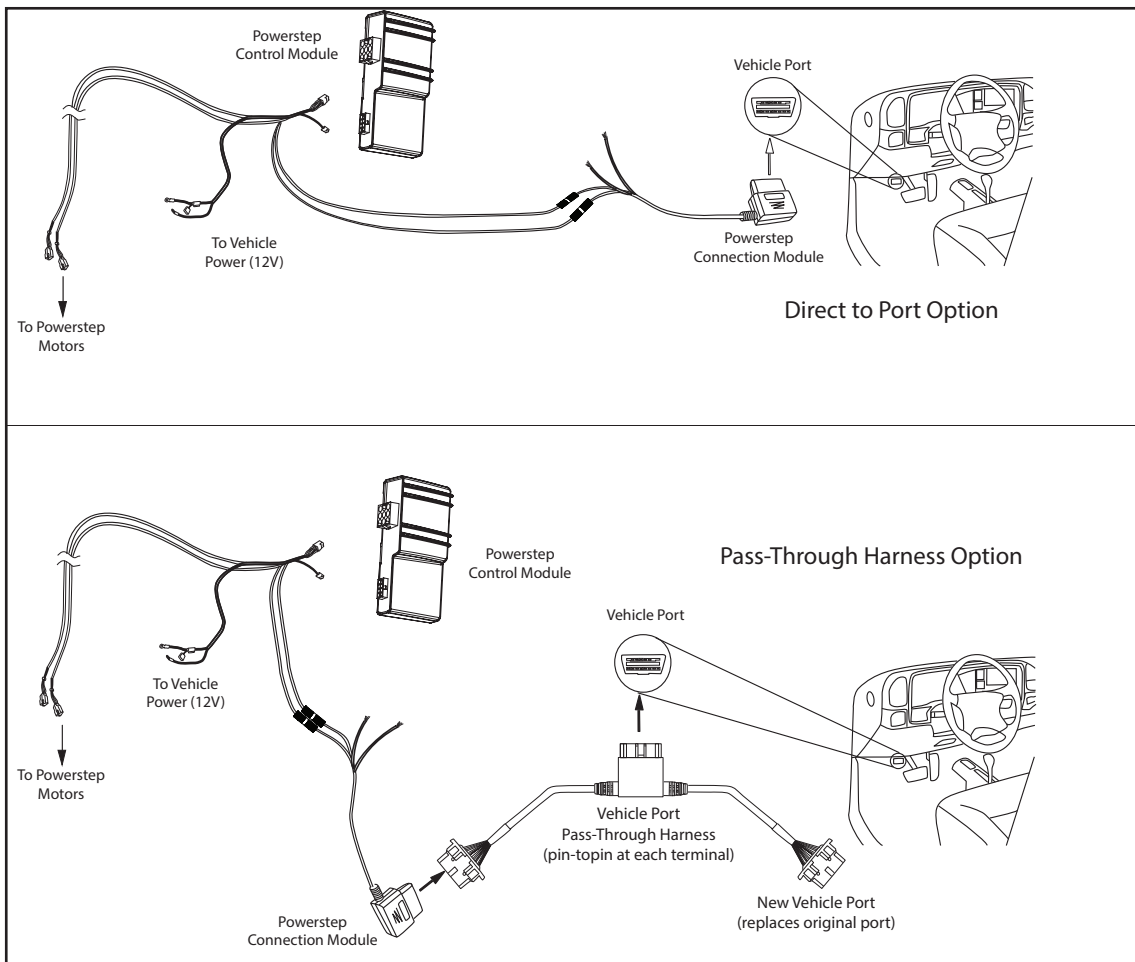

Attach motor to linkage. Using a 13mm wrench Torque to 36 in-lbs.
See page 2 for further instructions on attaching motor to linkage.

Note: Motor face forward on driver and passenger side.

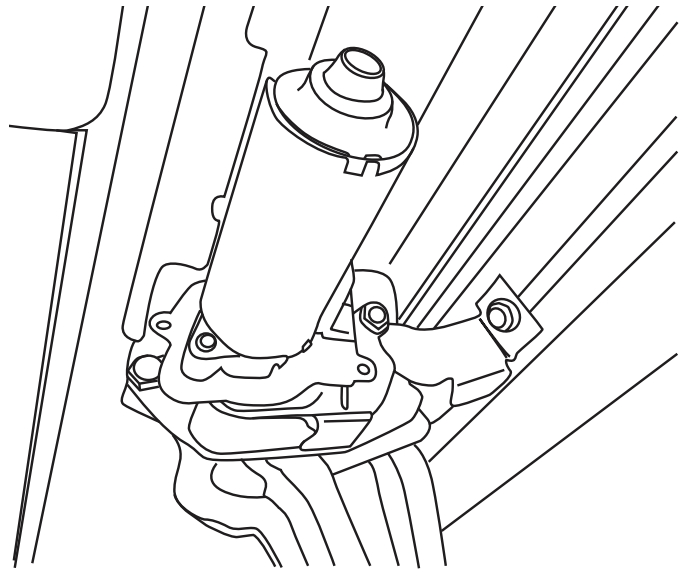

16

On driver side, run Wire Harness leg down and along underside of the vehicle floor and frame to rear Drive Linkage. Connect harness to motor and secure harness with tie wraps.

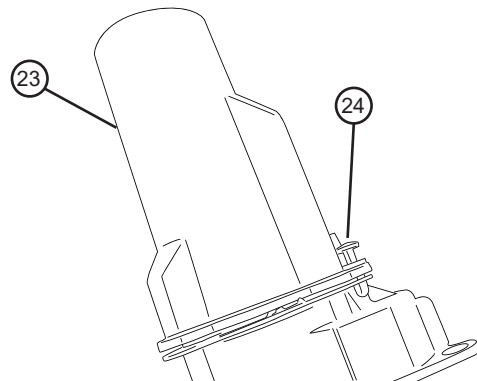
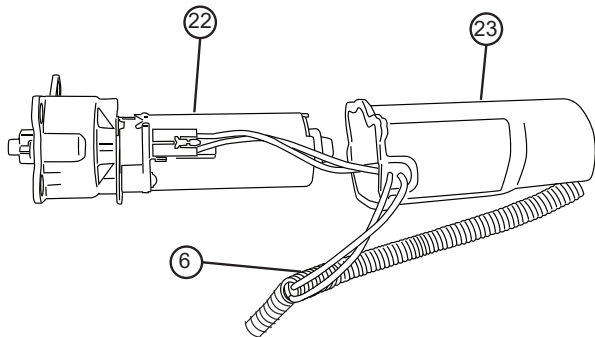

17

Affix LED Lamp (18) to Light Bracket (14) on rail. Slide bracket into desired position and tighten using 5/32" Allen key.

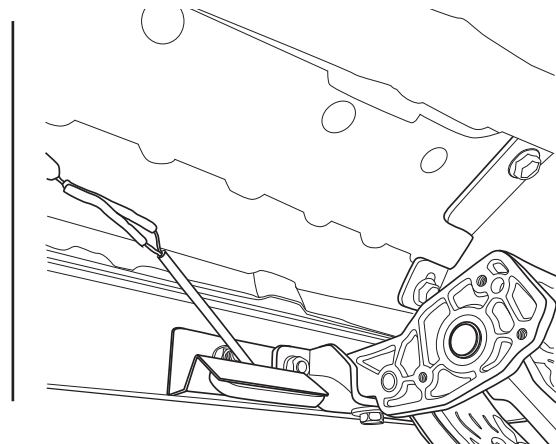
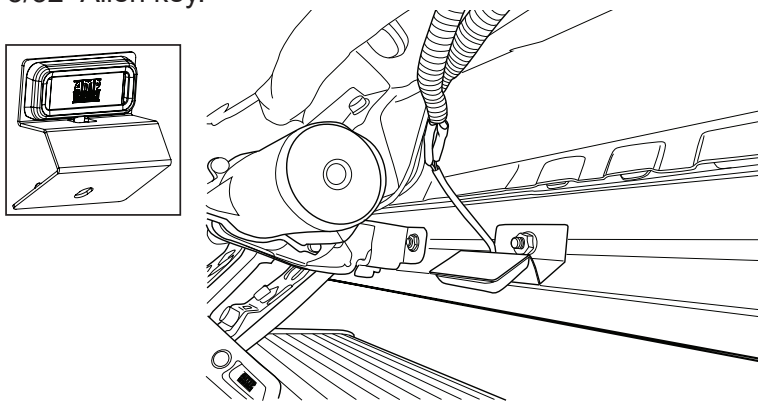

18

Using supplied butt connectors (19), connect the lamp wires. Red to Red, Black to Black. Once Crimped use heat gun to shrink tube. Close and wrap conduit with electrical tape. Secure all loose wires with zip ties (16). Pull lamp wires upward to avoid any wire snagging.

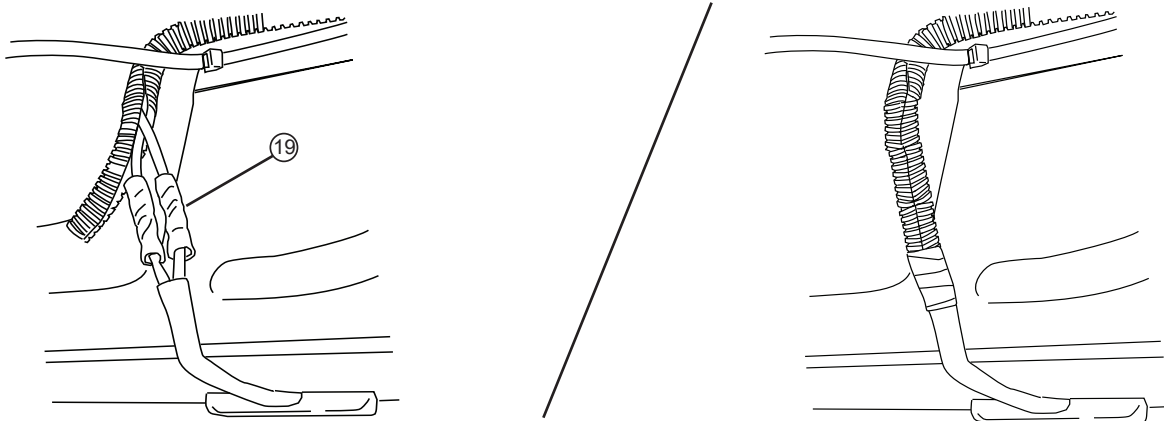

19

Check that all doors activate the Power Step and the LED Lights work when doors open and close. Reinstall any remaining trim panels.

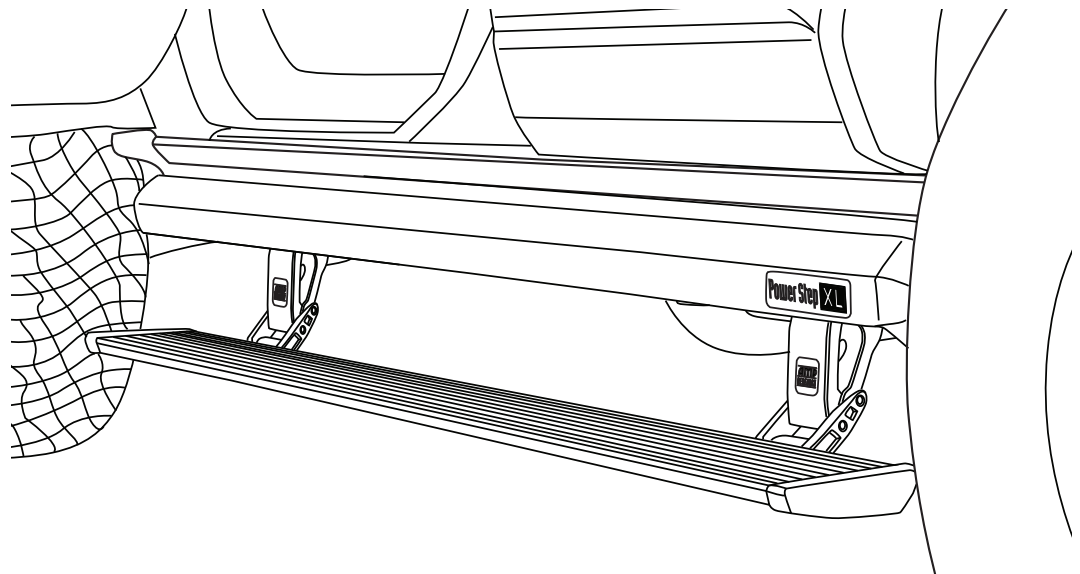
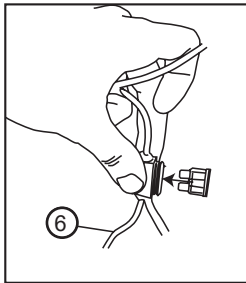

FINAL SYSTEM CHECK

Check that all doors activate the PowerStep and the LED lights work when doors open and close.

NORMAL OPERATION: When the doors open, PowerStep automatically deploys from under the vehicle. When the doors are closed, PowerStep will automatically return to the stowed/retracted position. **Note that there is a 2-second delay before the PowerStep returns to the stowed/retracted position.**

CORRECT OPERATION OF LIGHTS: All four lamps will illuminate upon opening any door of vehicle. Lamps will stay on until restowing of both Power Steps or until 5 minutes has expired with the doors open. When the lights timeout after 5 minutes, they can be reilluminated by closing and opening any door of vehicle.

20

AMP **RESEARCH** **Power Step**™

AMERICAN DESIGNED, ENGINEERED AND MANUFACTURED.

Thank you for your recent AMP Research Purchase.

REGISTER YOUR PRODUCT TODAY FOR FASTER SERVICE & PRODUCT UPDATES

Please visit:

www.amp-research.com/productregistration
or scan the QR Code



Product Registration Benefits:

- Ensure we have your purchase receipt and product info in our system which is required for warranty
- Faster and easier access to customer service and tech support in the unlikely event you need warranty or product support
- Registration helps us keep you up to date on product information and offers

To view other Amp Research products that may be offered for your vehicle.

Please visit: www.amp-research.com

Rev 01.05.21

POWER-DEPLOYABLE RUNNING BOARDS OPERATION: AMP Research PowerStep running boards automatically move when the doors are opened to assist entering and exiting the vehicle.

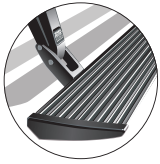

Automatic power deploy:

The running boards will extend down and out when the doors are opened.

Automatic power stow:

The running boards will return to the stowed position when the doors are closed. There will be a 2-second delay before the running boards move to the stowed position.

Automatic stop:

If an object is in the way of the moving running board, the running board will automatically stop. To reset, clear any obstruction, then simply open and close the door to resume normal operation.



Manually set in the deployed (OUT) position for access to the roof:

The running boards can be manually set in the deployed position by firmly holding the step down with your foot while at the same time closing the door. To resume normal operation, open and close the door.

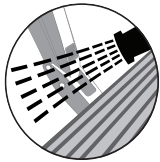

Maintenance: In adverse conditions, debris such as mud, dirt, and salt may become trapped in the running board mechanism, possibly leading to unwanted noise. If this occurs, manually set the running boards to the deployed position and flush the front and rear hinge arms with a high-pressure car wash wand. **Avoid spraying the motors directly.** After washing, apply silicone spray lubricant to the hinge pivot pins. Do not apply silicone, wax or protectants like Armor All® to the running board stepping surface.

Caution! Keep hands away when the running board is in motion.

5-YEAR LIMITED WARRANTY

AMP RESEARCH warrants this product to be free from defects in material and workmanship for FIVE (5) YEARS FROM DATE OF PURCHASE, provided there has been normal use and proper maintenance. This warranty applies to the original purchaser only. All remedies under this warranty are limited to the repair replacement of the product itself, or the repair or replacement of any component part thereof, found by the factory to be defective within the time period specified. The decision to repair or replace is wholly within the discretion of the manufacturer.

This warranty specifically excludes labor. If you have a warranty claim, first you must call our factory at the number below for instructions. You must retain proof of purchase and submit a copy with any items returned for warranty work. Upon completion of warranty work, if any, we will return the repaired or replaced item or items to you freight prepaid. Damage to our products caused by accidents, fire, vandalism, negligence, misinstallation, misuse, Acts of God, or by defective parts not manufactured by us, is not covered under this warranty.

ANY IMPLIED WARRANTIES OF MERCHANTABILITY AND/OR FITNESS FOR A PARTICULAR PURPOSE CREATED HEREBY ARE LIMITED IN DURATION TO THE SAME DURATION AND SCOPE AS THE EXPRESS WRITTEN WARRANTY. OUR COMPANY SHALL NOT BE LIABLE FOR ANY INCIDENTAL OR CONSEQUENTIAL DAMAGE.

Some states do not allow limitations on how long an implied warranty lasts, or the exclusion or limitation of incidental or consequential damages, so the above limitations or exclusions may not apply to you. This warranty gives you specific legal rights, and you may also have other rights that vary from state to state.

FOR WARRANTY ISSUES WITH THIS PRODUCT PLEASE CALL AMP RESEARCH TECH SUPPORT 1-888-983-2204

WARNING

Be sure to read and precisely follow the provided instructions when installing this product. Failure to do so could place the vehicle occupants in a potentially dangerous situation. After installing or reinstalling, re-check to insure that the product is properly installed.



The material that your product is made from can be recycled.
Please also consider recycling the packaging that your product came in.

