

# AMP RESEARCH Power Step

MADE IN USA

APPLICATION	LENGTH	MODEL YR	PART #
Ford F150 SuperCab *	72"	2009 - up	75141-01A
Ford F150 SuperCrew	79"	2009 - up	75141-01A

**\*Modification required to running board assembly. See Item 1 on page 3.**

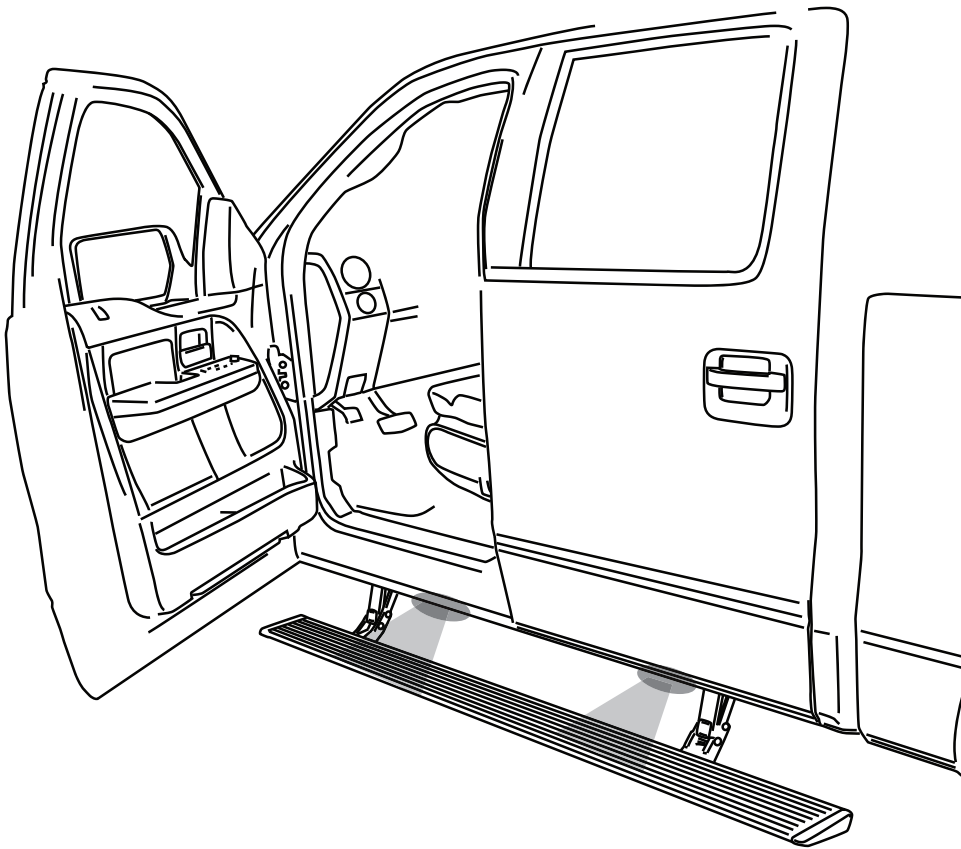

**INSTALLATION TIME**

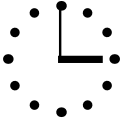

**3:00 hrs**

**SKILL LEVEL**

① ② ③ ④

4= Experienced

- TOOLS REQUIRED**
- Safety goggles
  - 8 mm socket
  - 10 mm socket
  - 13 mm socket
  - 13 mm end wrench
  - Ratchet wrench and extension
  - Wire stripper
  - 3/16" hex key wrench ( allen wrench)
  - 4mm hex key wrench ( allen wrench)
  - Electrical tape
  - Weather proof caulking ( silicone sealer )

**AMP RESEARCH TECH SUPPORT 1-888-983-2204 (Press 2) Monday - Friday, 6:00 AM - 5:00 PM PST**

Designed and manufactured by AMP Research®. Patent Number 6,830,257; 6,641,158; 6,834,875; 6,938,909; 6,942,233; 7,007,961; 7,055,839; 7,163,221; 7,367,574; 7,380,807; 7,398,985; 7,413,204; 7,487,986. Other US and Worldwide patents pending. Made in USA © 2010 AMP Research  
5-year limited warranty. Professional installation is recommended.

## INSTALLATION GUIDE

### Attaching motor to linkage assembly

The motors must be attached to the linkage assemblies before continuing the installation process.

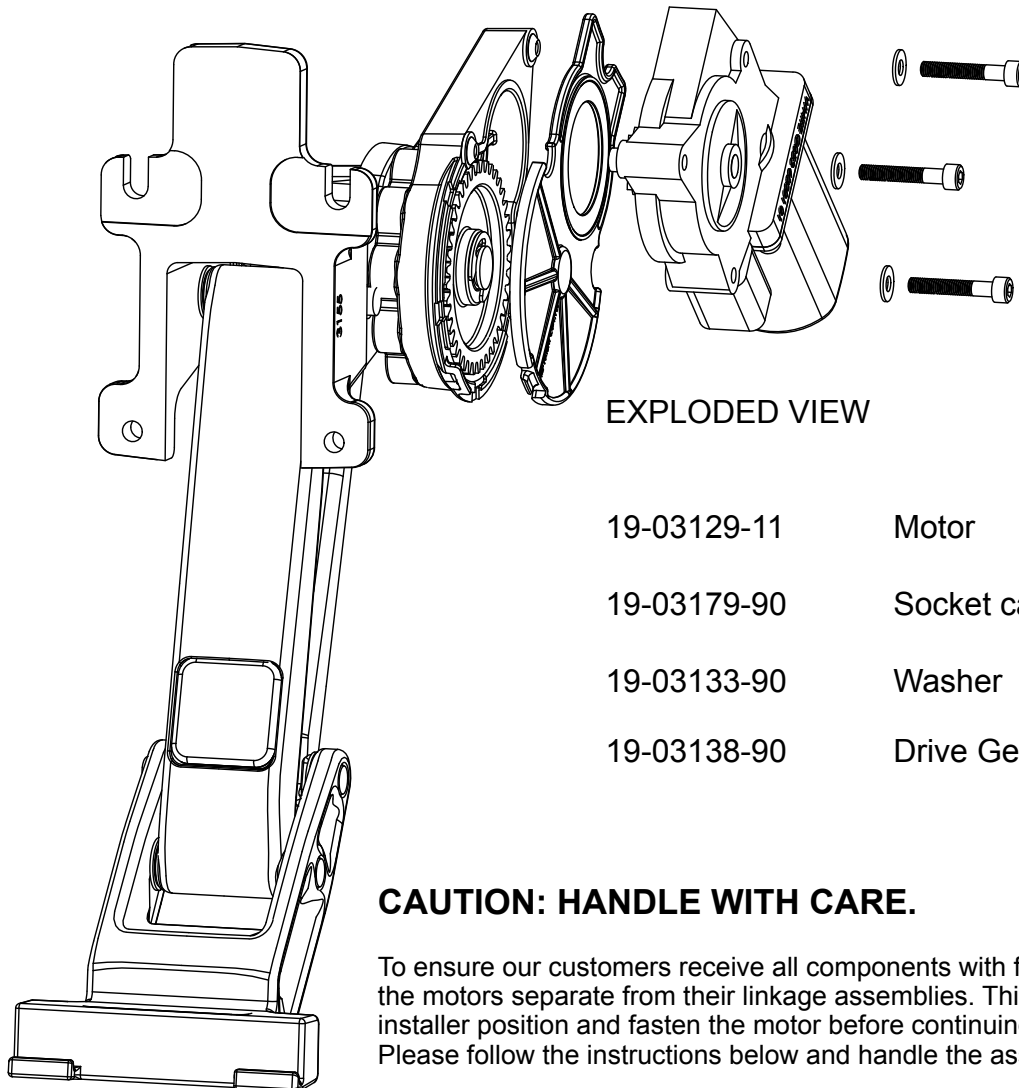

EXPLODED VIEW

19-03129-11	Motor
19-03179-90	Socket cap screw
19-03133-90	Washer
19-03138-90	Drive Gear Housing Cover

### CAUTION: HANDLE WITH CARE.

To ensure our customers receive all components with full integrity, we pack the motors separate from their linkage assemblies. This requires that the installer position and fasten the motor before continuing with the install. Please follow the instructions below and handle the assembly carefully.

CAUTION: Dropping the assembly or any excessive impact MAY cause damage to the motor.

#### Instructions:

1. Position the gear cover in place as shown if not already in place.
2. Seat motor into position on the three mounting bosses. This may require an adjustment of the gear by moving the swing arms.
3. After seating into place, fasten the motor with the three motor mount screws with 4mm Hex Head. Tighten screws to 36 in-lbs (4N-m). **Do not over torque.**

**Note: Some Applications require modification.**

**Application**

Super Crew  
Super Cab

**Cut Length**

79" (No Modification Required)  
72" (Trim 7")

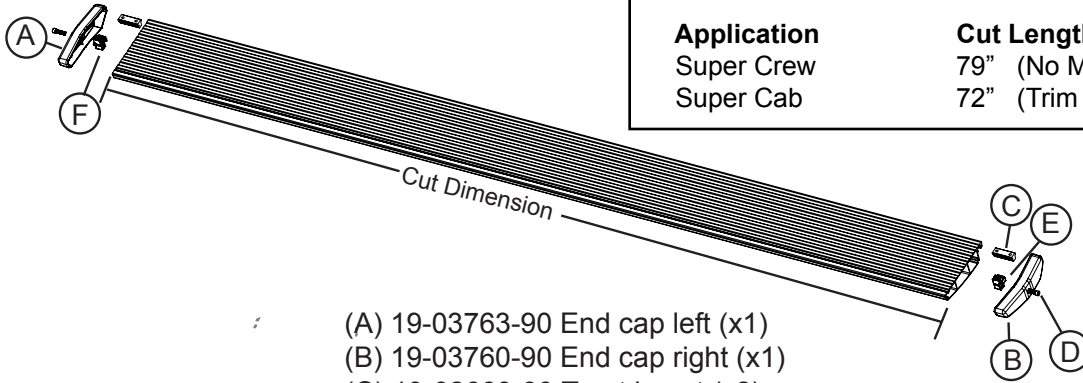

- (A) 19-03763-90 End cap left (x1)
- (B) 19-03760-90 End cap right (x1)
- (C) 19-02663-90 T-nut insert (x2)
- (D) 19-02802-90 Socket cap screw (x2)
- (E) 19-03761-90 End cap wedge right (x1)
- (F) 19-03764-90 End cap wedge left (x1)

**1** x2

Running board assembly

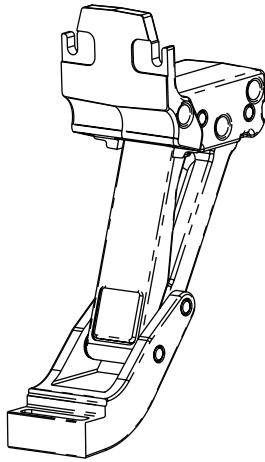

**2** x2

10-03007-11  
Idler linkage assembly

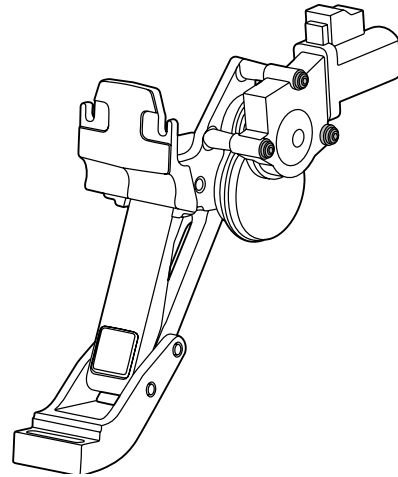

**3** x2

10-03006-11  
Motor linkage assembly

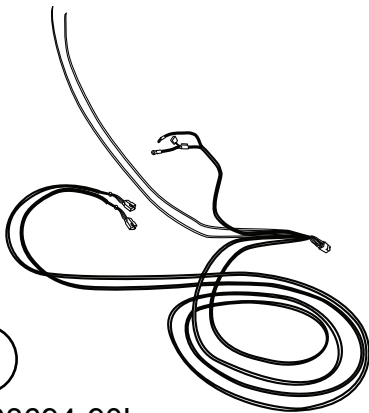

**4**

19-03694-90L  
Wire harness

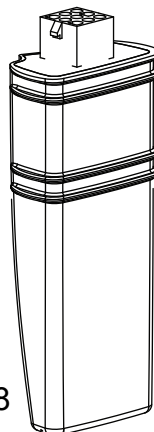

**5**

19-03297-98  
Controller

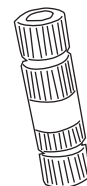

**6** x4

19-03354-90  
Posi-Tap™ (Red/Grey)

PARTS LIST AND  
HARDWARE  
IDENTIFICATION

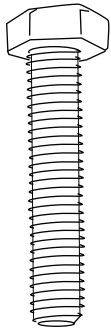

**7** x8  
19-02487-90  
Hex bolt

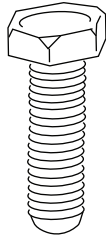

**8** x 8  
19-02849-90  
Hex Bolt

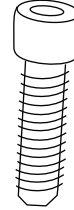

**9** x8  
19-02802-90  
Socket cap screw



**11** x8  
19-02488-90  
U-nut

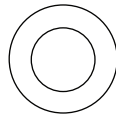

**12** x16  
16-03014-90  
Washer Black

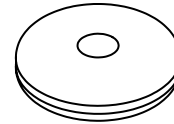

**13**  
19-03699-90  
Grommet



**14** x20  
19-02805-90  
Cable Ties 7"

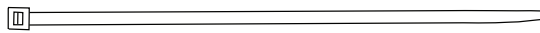

**15** x2  
19-03339-90  
Cable Ties 11"

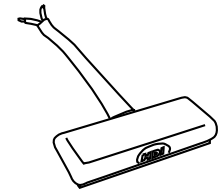

**16** x4  
19-03302-90  
LED Lamp

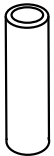

**17** x8  
19-02989-90  
Butt Connector

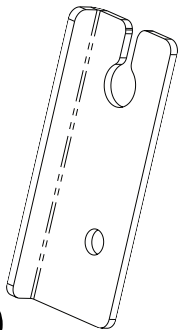

**18**  
16-03048-90  
Bracket

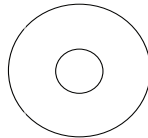

**19**  
19-02389-90  
Washer

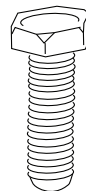

**20**  
19-02849-90  
Hex Bolt



**21**  
10-00115-60  
Nylock Nut

Mount brake cable bracket extension and then raise brake cable into position.  
 Note: First pull brake cable downward to create slack before raising into position.

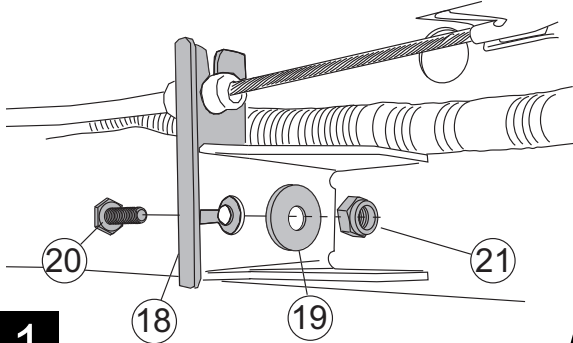

1

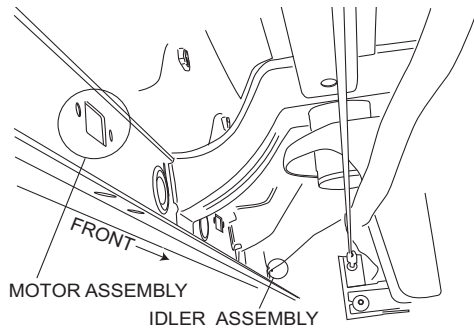

Locate mounting points; first and last set of holes on the inner sill.

Motor Linkage mounts toward the rear of the truck, with the exception of the passenger side on SuperCab trucks. Mount the motor linkage in front on the passenger side of SuperCab trucks.

Install J-clips and start bolts with washers installed.

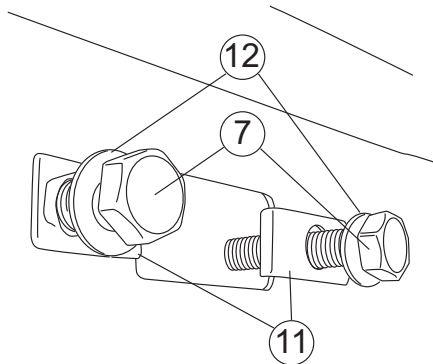

2

Mount idler assembly and motor assembly. Note: Filing of sheet metal edge may be required if the sheet metal holes are misaligned.

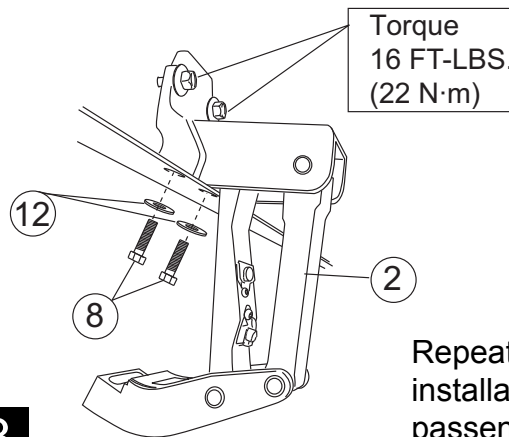

3

Repeat linkage installation on passenger side

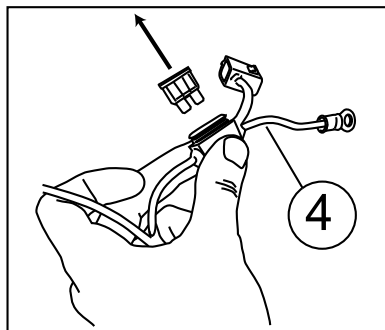

Remove fuse from wire harness

4

Attach wire harness to controller (make sure connector locking tabs fully engage). Mount controller with the two 11" tie wraps to factory conduit.

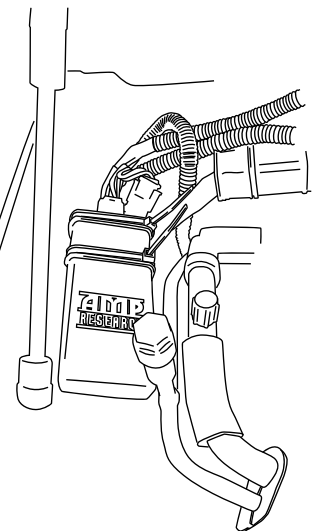

5

Connect red and black power leads to battery. Red lead goes to positive. Route shorter leg of harness down passenger-side wheel well.

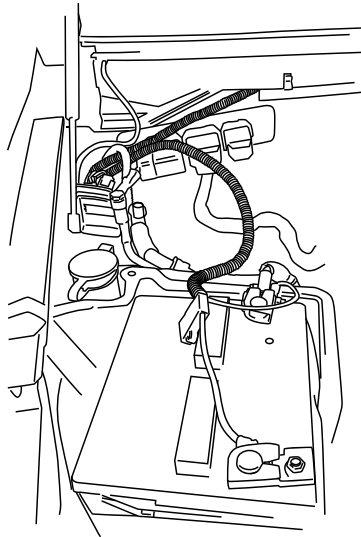

6

Route longer wire harness leg across firewall through plastic cowling to driver side.

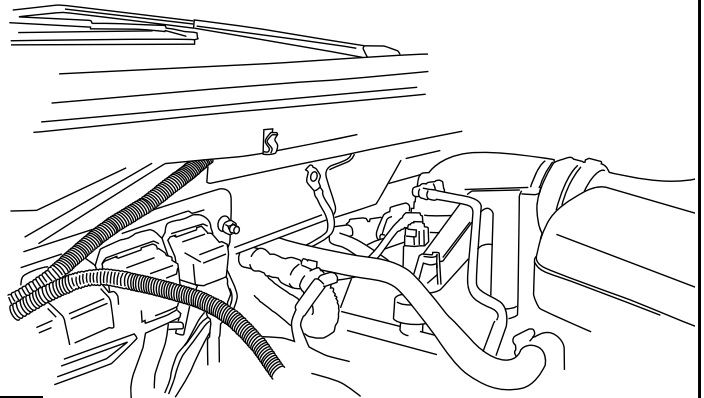

7

Route longer leg of harness down along driver-side wheel well and along frame of vehicle. Secure with tie wraps.

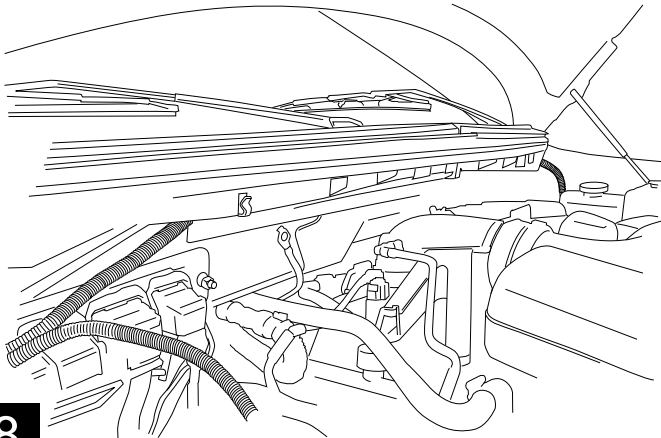

8

Remove passenger side front kick panel and door sill plate. Roll back carpet to access hole for grommet installation.

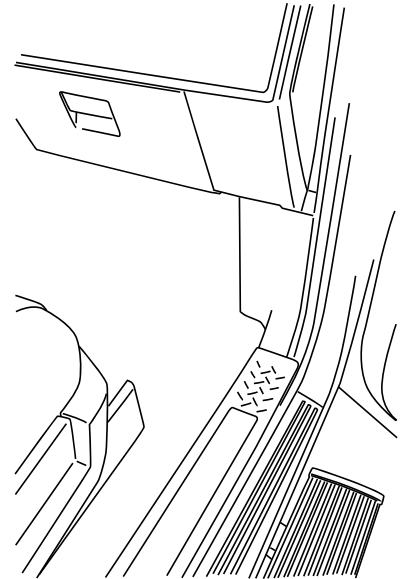

9

Remove tape from 3/4" hole in floor panel above front linkage on passenger side and insert grommet. Thread all four trigger wires through grommet up into the cabin of vehicle. Seal grommet with silicone sealer.

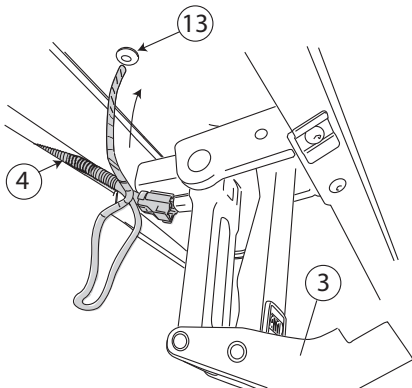

10

Wiring connections are located under the passenger side kick panel.

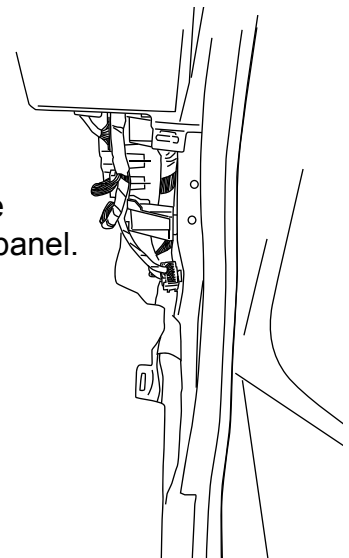

11

Locate this **small** connector, highlighted in gray, and unplug for improved access during wire connection. Plug may vary among model years.

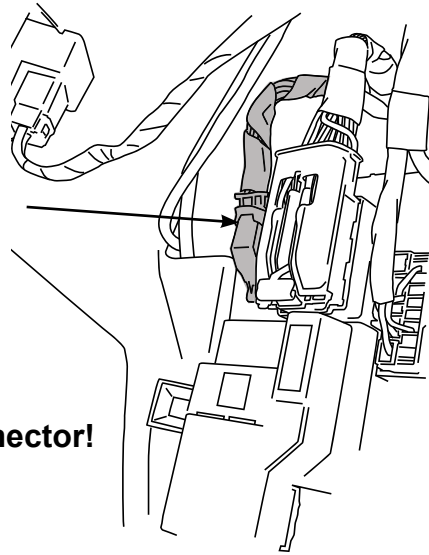

**Not the big connector!**

**12**

**Posi-Tap instructions**

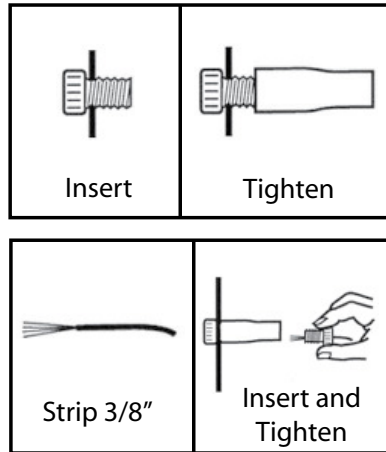

**13**

Using supplied Posi-Tap connectors, connect Power Step trigger wires to like colored wires in factory wire harness as shown in step 15.

	SuperCrew	SuperCab	Regular Cab
Driver Front	Green/Violet	Green/Violet	Green/Violet
Pass. Front	White	White	White
Driver Rear	Green		
Pass. Rear	Yellow		

For **SuperCab** and **Regular Cab** connect the two extra trigger wires to the same wires listed above, Green connects to Green/Violet and Yellow connects to White.

Make certain each Posi-Tap is making positive contact with the copper wire inside the insulation. Re-connect factory wire harness from step 12.

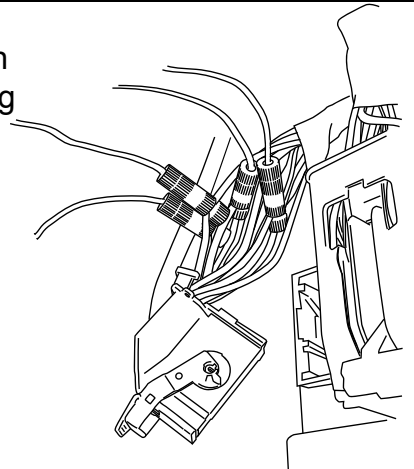

As stated in step 12, connector style varies among model years... may or may not have locking lever.

**14**

Attach step, sliding the mounting T-nut into position.

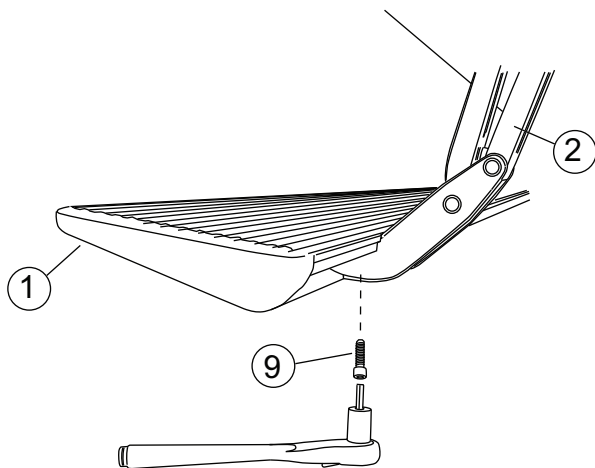

**16**

**15**

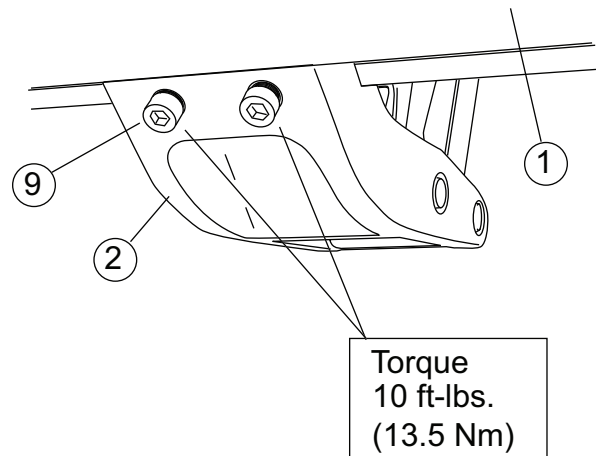

**17**

Route wire harness towards rear of vehicle inside body support gussets. Secure using supplied cable ties. Run wire harness to rear motor assembly and insert plug onto motor.

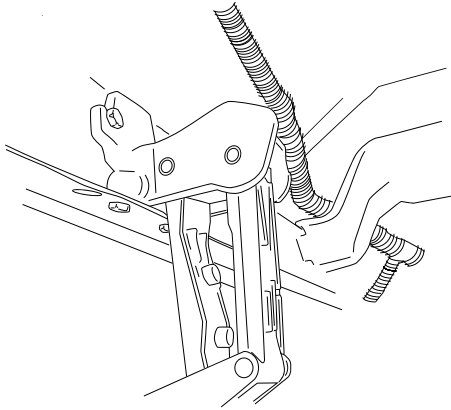

18

On each side of the vehicle measure from the front edge of door line on the pinch weld to the specified lengths below. Measure at 24" for front LED Light and 65" for rear LED Light.

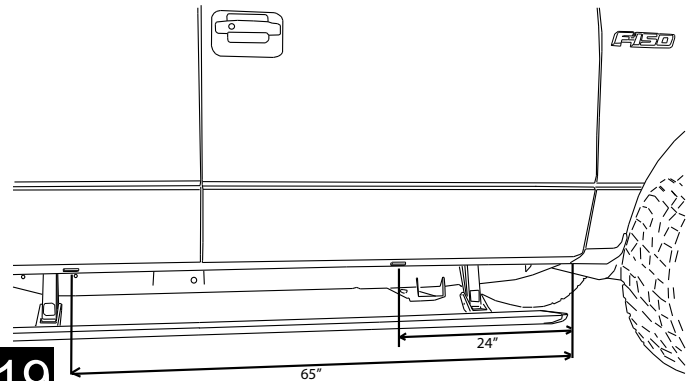

19

Affix lamps to rocker panel surface. Make sure the lamp is affixed to a clean, flat surface. There is a step down midway across the surface. Affix lamp just outside of step down.

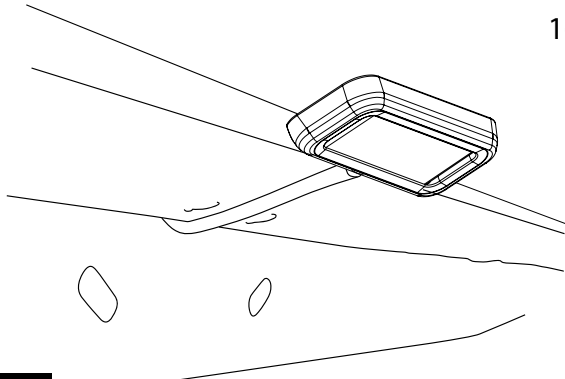

16

20

Using supplied butt connectors, connect the lamp wires. Red to Red, Black to Black

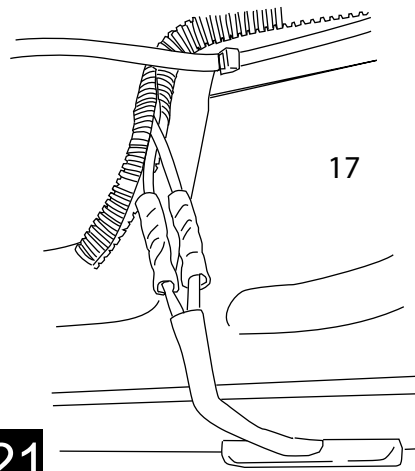

17

21

Close and wrap with conduit and electrical tape. Secure all loose wires with cable ties, with lamp wires pulled upward to avoid any wire snagging.

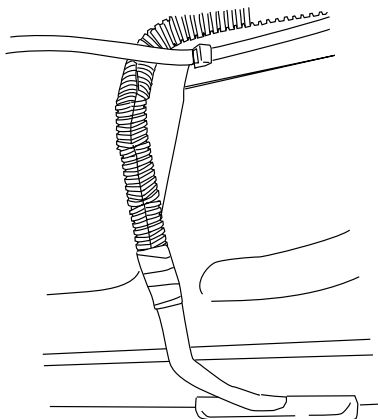

22

Replace fuse.

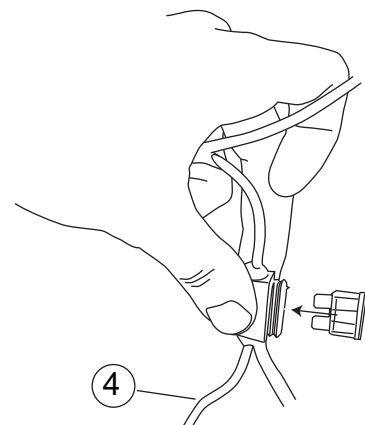

4

23



Check that all door activate the Power Step and the LED Lights work when doors open and close. Reinstall any remaining trim panels.



**Correct operation of Lights:** All four lamps will illuminate upon opening any door of vehicle. Lamps will stay on until restowing of both Power Steps or until 5 minutes has expired with the doors open. When the lights timeout after 5 minutes, they can be reilluminated by closing and opening any door of vehicle.



Congratulations on your purchase of the genuine AMP Research PowerStep!  
Here's what you should know...

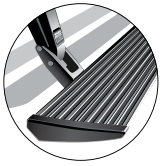

**POWERSTEP™ OPERATION** - The AMP Research PowerStep™ automatically deploys when any door is opened. When both front and rear doors are closed, it retracts automatically under your vehicle.

**The drive system is designed to automatically stop if resistance, blockage or icing occurs.**  
To reset, clear any obstruction, then simply open and close the door and normal operation will resume.

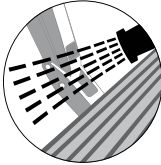

**MAINTENANCE TIPS** - The stepping surface and linkages should be periodically washed with mild soap and water using a soft brush or sponge to dislodge any mud, dirt or accumulated road grime.

**In severe driving conditions, pressure washing the linkages is strongly recommended.**  
Avoid spraying the motors directly with high-pressure water. After washing, apply Silicone spray lubricant to the pivot pins of each linkage assembly. Remove any excess lubricant with a soft clean cloth. Do not apply Silicone spray, waxes or protectants like Armor All® to the stepping surfaces.



**KEEPING POWERSTEP™ DEPLOYED** - When washing your vehicle, the PowerStep can be set to remain in the deployed position with the doors closed. **DO THIS...**

1. With the PowerStep deployed, firmly press and hold the step down with your foot.
2. Close the door while continuing to press down on the step. *(This will not harm the motor.)*
3. To resume normal operation, simply open and close the door. *(Repeat for both sides of the vehicle.)*

**CAUTION! KEEP HANDS AWAY WHEN THE POWERSTEP IS IN MOTION**

### AMP RESEARCH LIMITED WARRANTY

AMP RESEARCH warrants this product to be free from defects in material and workmanship for FIVE (5) YEARS FROM DATE OF PURCHASE, provided there has been normal use and proper maintenance. This warranty applies to the original purchaser only. All remedies under this warranty are limited to the repair replacement of the product itself, or the repair or replacement of any component part thereof, found by the factory to be defective within the time period specified. The decision to repair or replace is wholly within the discretion of the manufacturer.

This warranty specifically excludes labor. If you have a warranty claim, first you must call our factory at the number below for instructions. You must retain proof of purchase and submit a copy with any items returned for warranty work. Upon completion of warranty work, if any, we will return the repaired or replaced item or items to you freight prepaid. Damage to our products caused by accidents, fire, vandalism, negligence, misinstallation, misuse, Acts of God, or by defective parts not manufactured by us, is not covered under this warranty.

ANY IMPLIED WARRANTIES OF MERCHANTABILITY AND/OR FITNESS FOR A PARTICULAR PURPOSE CREATED HEREBY ARE LIMITED IN DURATION TO THE SAME DURATION AND SCOPE AS THE EXPRESS WRITTEN WARRANTY. OUR COMPANY SHALL NOT BE LIABLE FOR ANY INCIDENTAL OR CONSEQUENTIAL DAMAGE.

Some states do not allow limitations on how long an implied warranty lasts, or the exclusion or limitation of incidental or consequential damages, so the above limitations or exclusions may not apply to you. This warranty gives you specific legal rights, and you may also have other rights that vary from state to state.

**FOR WARRANTY ISSUES WITH THIS PRODUCT PLEASE CALL AMP RESEARCH CUSTOMER SERVICE 1-800-315-9697**

### WARNING

Be sure to read and precisely follow the provided instructions when installing this product. Failure to do so could place the vehicle occupants in a potentially dangerous situation. After installing or reinstalling, re-check to insure that the product is properly installed.