

AMP RESEARCH BedStep 2™

Dodge Ram DR
1500 (2002-2008)
2500/3500 (2003-2009)
(Includes Dually applications)

PART NUMBER:
75404-01A

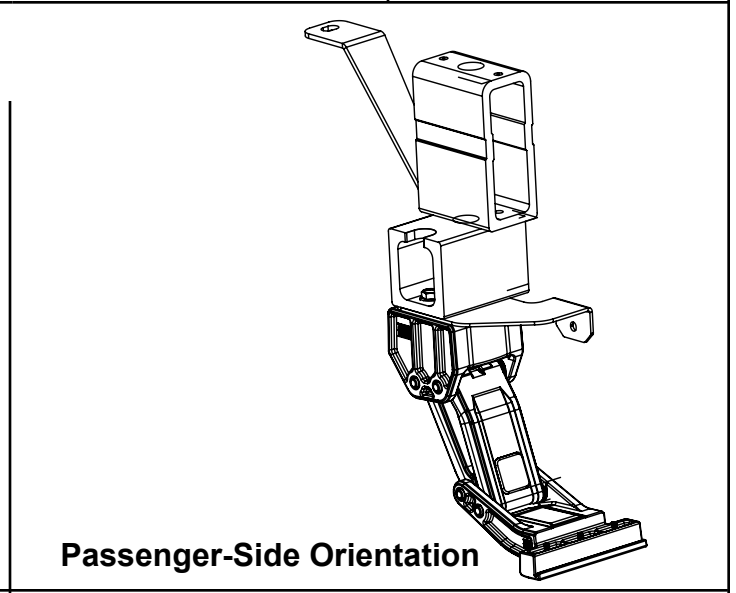
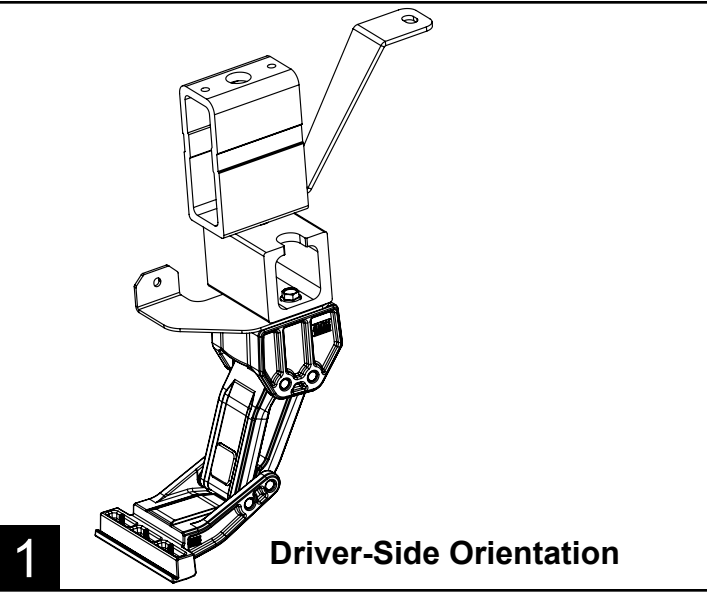
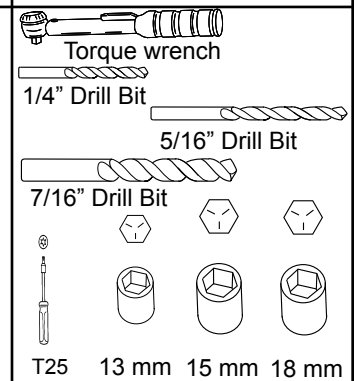
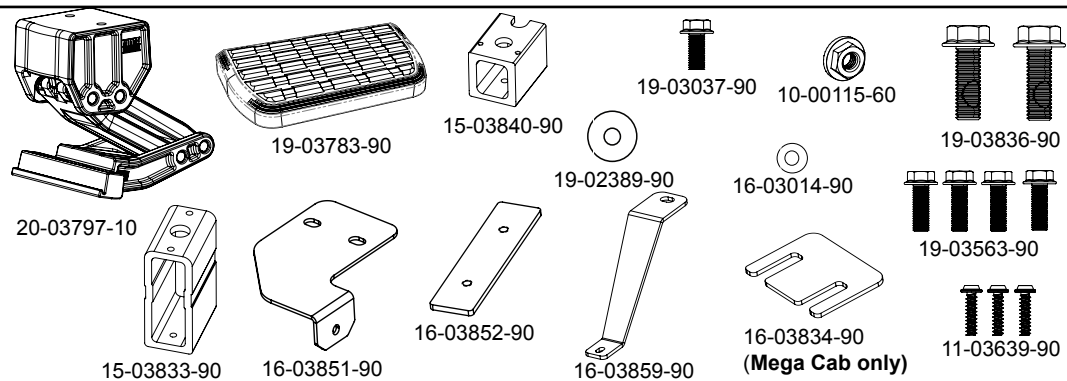

Use supplied drill template (See page 4) and mark holes in front bed channel mount. Pre drill holes using 1/4" drill bit. Next drill hole to 7/16".

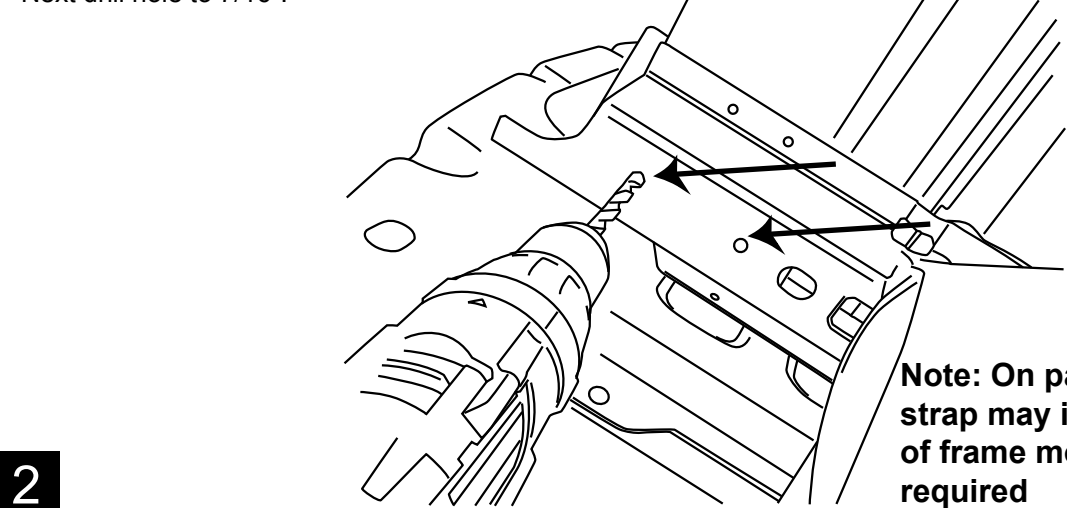

2 **Note: On passenger side Ground strap may interfere with mounting of frame mount. Relocation may be required**

AMP RESEARCH TECH SUPPORT 1-888-983-2204 (Press 2) Monday - Friday, 6:00 AM - 5:00 PM PST

BedStep2™ is invented, designed, engineered and manufactured exclusively by AMP Research and may be covered by one of the following patents: 6,641,158; 6,830,257; 6,938,909; 7,055,839; 7,380,807; 7,398,985; 7,584,975. Made in USA © 2011 AMP Research
Three-year limited warranty. Professional installation is recommended.

Using a 15mm Socket assemble Lateral mount onto linkage. Steel bracket is to be assembled between linkage and lateral mount. **Do not tighten bolts yet.** Drivers side orientation show. Mirror for passenger side.

Note: Mega Cab applications need provided spacer 15-03834-90. Place spacer between linkage and steel bracket.

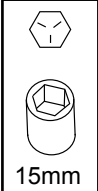
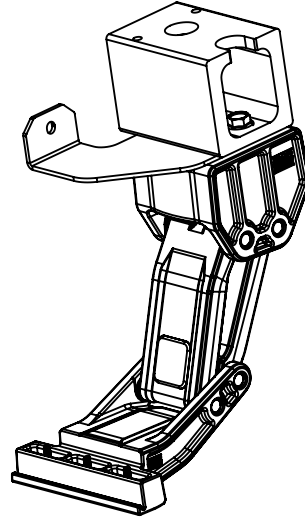

3

Using a 13mm Socket assemble Frame mount. Do not tighten bolts. Steel bracket will need to be adjusted to mount up to bed mount bolt.

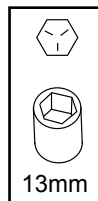
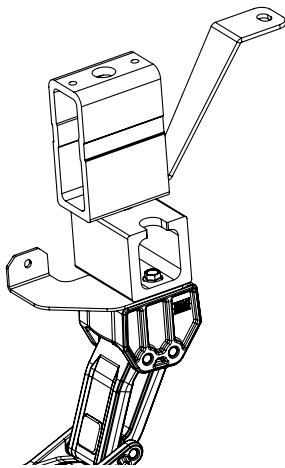

4

Slide threaded plate into bed channel and line up threaded locations to pre drilled holes.

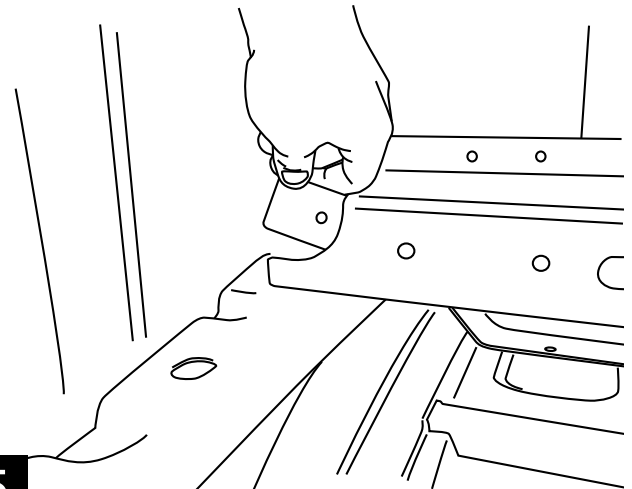

5

Using a 18mm Socket assemble Frame mount bracket to bed mount bolt. Do not tighten bolts

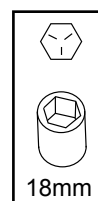
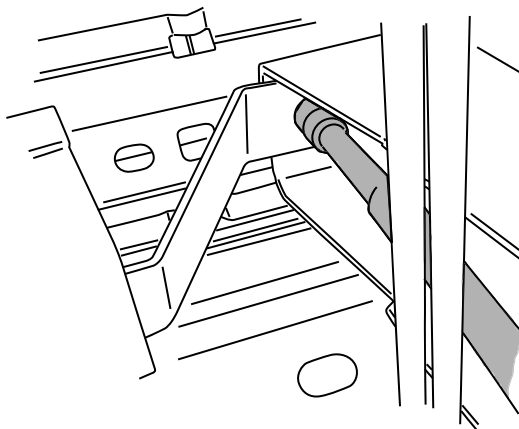

6

Using 13mm Socket tighten 2 bolts holding Frame mount to bed channel. Do not tighten bolts

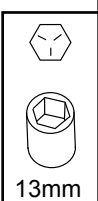
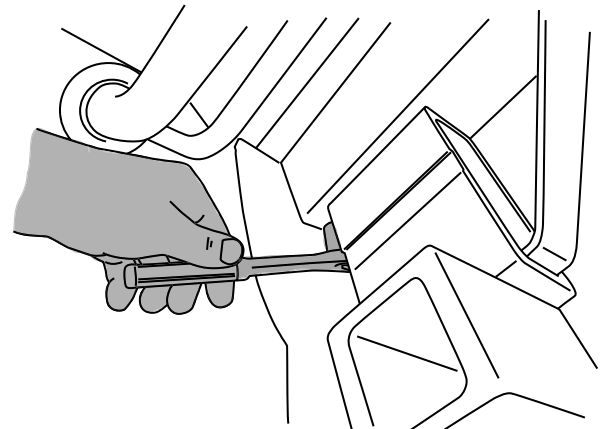

7

Slide Support bracket up to bed sheetmetal. Drill using 5/16 drill bit.

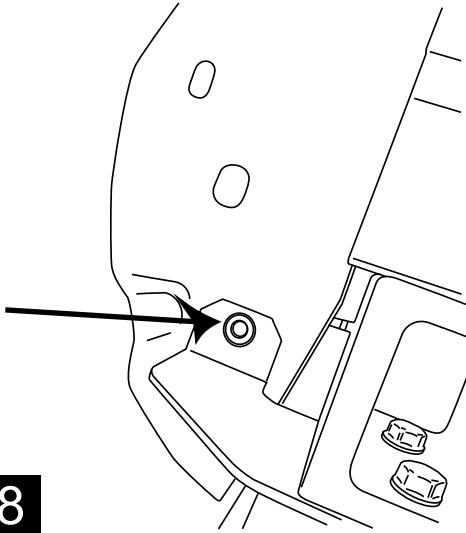

8

Use 13mm socket and wrench tighten bolt using fender washer. Torque to 16 ft-lbs.

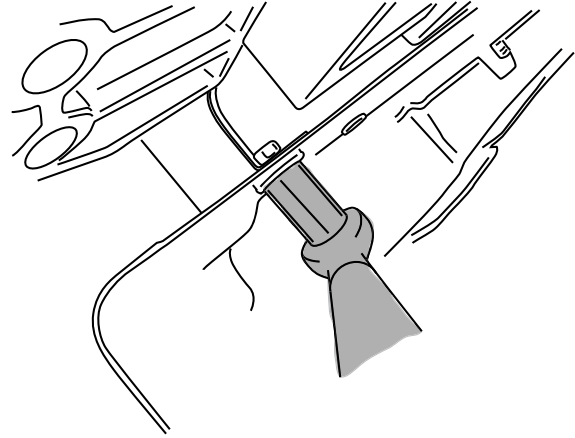

9

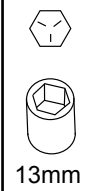

13mm

Use 15mm socket tighten bolts that mount the linkage to the lateral mount. Torque to 20 ft-lbs.

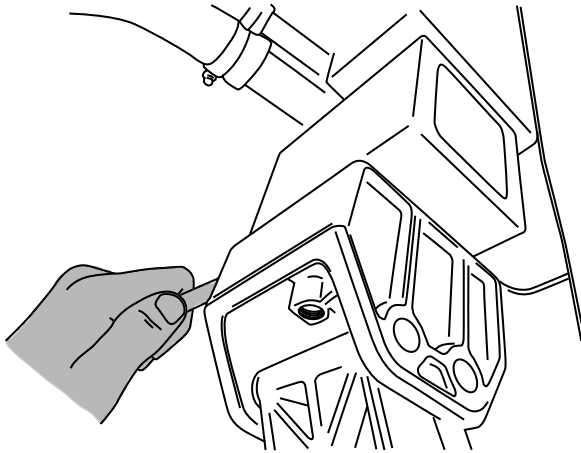

10

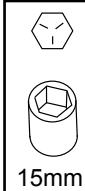

15mm

Using a 13mm socket tighten two bolts holding Frame mount to bed channel. Also tighten bolt that attaches frame bracket to frame mount Torque to 16 ft-lbs.

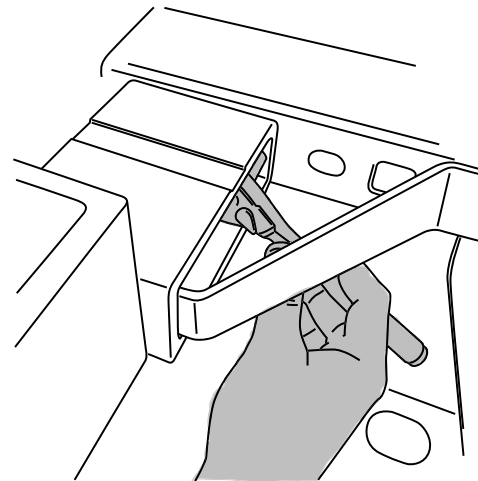

11

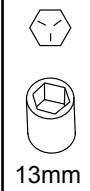

13mm

Using a 18mm Socket torque bolt to 40 ft-lbs.

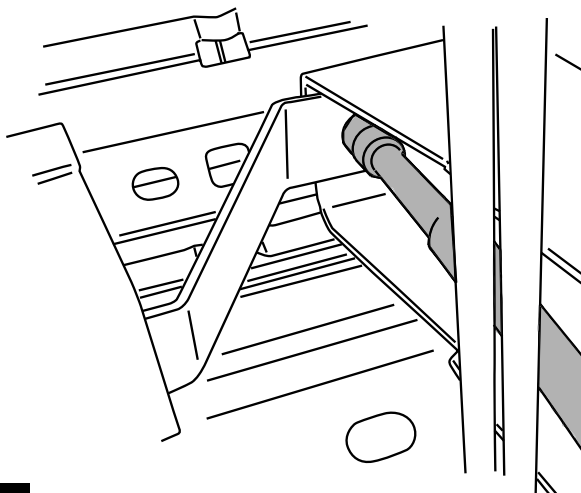

12

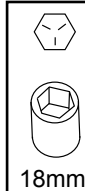

18mm

Locate the step pad in center position. Use T25 Torx driver or bit to tighten screws.

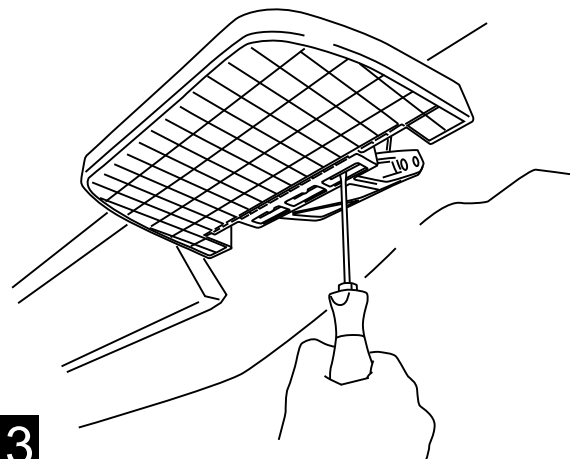

13

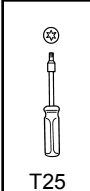

T25

To deploy the step, press down using your foot on the outside edge of the step pad.

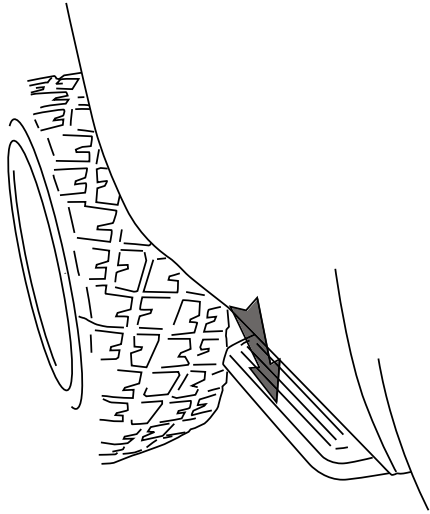

14

To retract, gently kick up on the underside of the step pad.

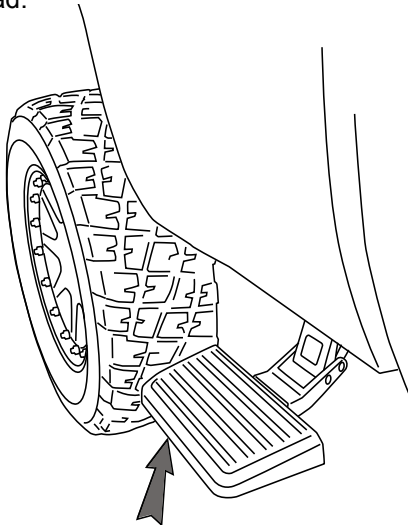

Note: If linkage or step pad comes in contact with the body use provided washer. Remove white bumper between linkage arms and insert washer and replace bumper.

15

DRILL TEMPLATE

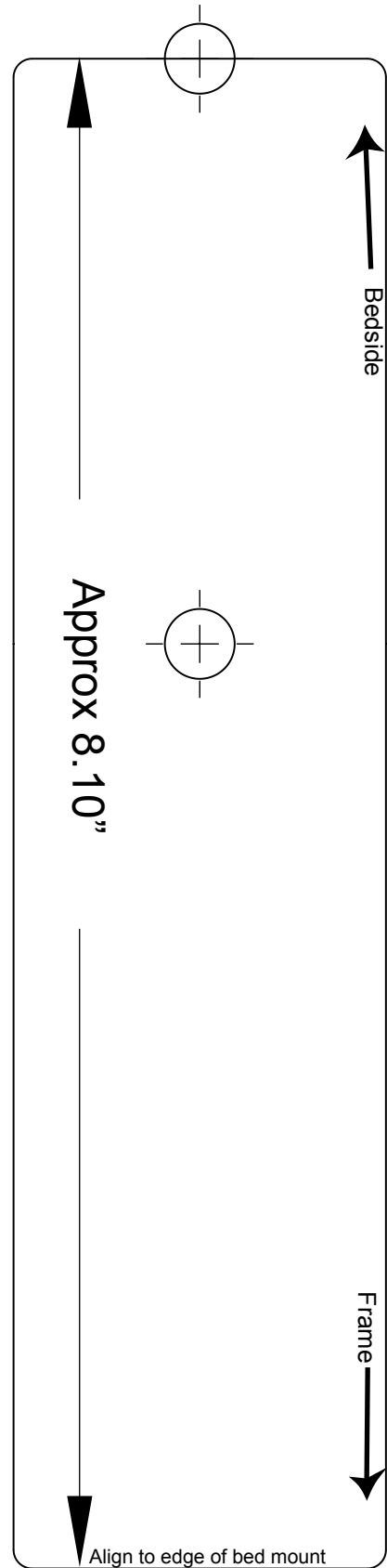



Congratulations on your purchase of the genuine AMP Research BedStep2™. Here's what you should know...

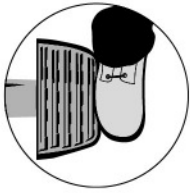

BEDSTEP2™ OPERATION

The AMP Research BedStep2™ is foot operated and deploys and retracts with a nudge of your foot. To deploy, press down using your foot, on the outside edge of the step pad.

Maximum load capacity of the deployed step pad is 300 lbs.

Always use appropriate hand holds when stepping up to or down from your truck's cargo bed.



To retract, gently kick up on the underside of the step pad.

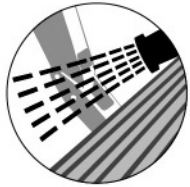

MAINTENANCE TIPS - The stepping surface and linkage should be periodically washed with mild soap and water using a soft brush or sponge to dislodge any mud, dirt or accumulated road grime.

In severe driving conditions, pressure washing the linkage is strongly recommended.

Do not apply silicone spray, waxes or protectants like Armor All® to the stepping surfaces.

CAUTION! BEDSTEP2™ SHOULD ALWAYS BE STOWED IN THE RETRACTED POSITION WHEN DRIVING.

AMP RESEARCH LIMITED WARRANTY

AMP RESEARCH warrants this product to be free from defects in material and workmanship for THREE (3) YEARS FROM DATE OF PURCHASE, provided there has been normal use and proper maintenance. This warranty applies to the original purchaser only. All remedies under this warranty are limited to the repair replacement of the product itself, or the repair or replacement of any component part thereof, found by the factory to be defective within the time period specified. The decision to repair or replace is wholly within the discretion of the manufacturer.

This warranty specifically excludes labor. If you have a warranty claim, first you must call our factory at the number below for instructions. You must retain proof of purchase and submit a copy with any items returned for warranty work. Upon completion of warranty work, if any, we will return the repaired or replaced item or items to you freight prepaid. Damage to our products caused by accidents, fire, vandalism, negligence, misinstallation, misuse, Acts of God, or by defective parts not manufactured by us, is not covered under this warranty.

ANY IMPLIED WARRANTIES OF MERCHANTABILITY AND/OR FITNESS FOR A PARTICULAR PURPOSE CREATED HEREBY ARE LIMITED IN DURATION TO THE SAME DURATION AND SCOPE AS THE EXPRESS WRITTEN WARRANTY. OUR COMPANY SHALL NOT BE LIABLE FOR ANY INCIDENTAL OR CONSEQUENTIAL DAMAGE.

Some states do not allow limitations on how long an implied warranty lasts, or the exclusion or limitation of incidental or consequential damages, so the above limitations or exclusions may not apply to you. This warranty gives you specific legal rights, and you may also have other rights that vary from state to state.

FOR WARRANTY ISSUES WITH THIS PRODUCT PLEASE CALL AMP RESEARCH CUSTOMER SERVICE 1-888-983-2204

WARNING

Be sure to read and precisely follow the provided instructions when installing this product. Failure to do so could place the vehicle occupants in a potentially dangerous situation. After installing or reinstalling, re-check to insure that the product is properly installed.